

CRAFTEC

Technical Engineering Notes



Craftec
A member of the Powerbox Group®

MARIALINDA COUR

The following technical notes are intended as a background guide to assist users of power conversion equipment. They are not intended to be a rigorous or complete treatment. Every effort has been made to incorporate information which is up to date bearing in mind the delay between authorship and publication, Crafterc categorically disclaim any responsibility for errors in content or interpretation. Customers are strongly advised to obtain the latest copies of the official documents relevant to the equipment type with which they are concerned.

© Crafterc AB



..... Using Power Converters 4



..... Safety Standards 7



..... Electro Magnetic Compatibility (EMC) 11



..... Testing Power Converters 12



..... Power Conversion Basic Topologies 19



..... Glossary of Terms 28

Even when the correct power converter(s) have been chosen from the wide product range in the POWERBOX POWER CONVERSION GUIDE, if care is not taken with installation and the design of the distribution wiring problems can arise. Often difficulties which at first appear to be power supply shortcomings are due to incorrect power distribution. Typical symptoms are poor regulation at the load, low voltage at the load, inadequate noise margins, excessive crosstalk between circuits, oscillatory behaviour and overheating.

Some important guidelines which help to avoid such problems are summarised as follows:

- Be on the generous side when selecting equipment wire ratings
- Keep all wiring as short as possible
- Connect signal and power zero volt common conductors separately to a single star earth connection
- Avoid creating additional earth connections by careless use of mounting screws, stand offs, brackets etc.
- Do not bundle wires together in looms indiscriminately
- Use separate twisted pairs for output/return wires
- Keep unfiltered mains input wiring outside the equipment - where this is impossible use short runs of twisted pairs, if necessary shielded by a grounded conductive sheath
- Ensure that mounting screws do not bridge safety clearance distances
- Never switch on power until the safety earth continuity has been checked
- Keep ventilation slots clear – excess operating temperatures are the major cause of unreliability – force cool when in doubt

Equipment Wire Rating

Examination of the effects of wiring resistance on regulation for the simple case of a single power converter connected to a single load show how easy it is to degrade regulation performance in circuits with modest power requirements.

No. of strands x diameter / strand (mm)	Near equivalent AWG	Typical specific resistance moHm/ m at 20°C
7 x 0.2	24	88
16 x 0.2	22	40
24 x 0.2	20	25
32 x 0.2	18	20

Multi-stranded tinned copper equipment wire

AWG	Approx diameter mm	Near equivalent SWG	Typical specific resistance moHm/ m at 20°C
14	1.60	16	8.3
18	1.00	19	21
22	0.64	23	53
26	0.40	27	133
30	0.25	31	338

Single strand annealed copper connecting wire

Table 1. Resistivity of popular sizes of equipment wire

Assume a 5A load is a half metre away from a 5V converter and the equipment wire (18 AWG) has a specific resistance of 20mΩ/metre. Total additional loop resistance is 20mΩ so the volts drop at full load is $5 \times 20 \times 10^{-3}$ volts i.e. 0.1V, 2% of the nominal output voltage. Load regulation has been degraded by a factor of 20 times, if the converter load regulation is specified as 0.1% at the output terminals. If for the sake of neatness the interconnect wire is taken around the periphery of an equipment box, at least a further half metre could be added to the two wires, increasing the total volts drop to 0.2V. At 4.8V, compared with 4.75V minimum supply voltage specified for many logic circuits there would be no margin left for further voltage reduction due to temperature coefficient, initial setting error or long term drift.

Connectors and Printed Circuit Boards

Connectors and printed circuit boards are major causes of excessive voltage drops in power distribution systems. Connectors give problems because of inadequate contact rating and lack of cleanliness. Corrosion, dust and dirt must be removed, otherwise local heating can eventually have a runaway effect with total breakdown of the contact. Where parallel pins are provided at the output of a power converter all the pins should be used for power distribution. On printed circuit boards, because of the pressure on the designer for high packing densities, power bus and zero volt tracks often become too narrow. Rather than suffer the consequences of this, the system designer should insist on adding low impedance power distribution buses in the form of vertically mounting conductive strips. When allocating pin assignments in PCB connectors it is essential to use sufficient numbers of pins to the power circuits.

Remote Sensing

Many power converters, especially those with higher current ratings and low output voltages incorporate remote sensing. This feature enables the voltage at the load, rather than at the converter output to be fed back for comparison with the internal reference to provide the difference signal for regulation. By this means the voltage at the load is regulated, and voltage drops in the connecting wires are automatically compensated. This results in a higher voltage than nominal at the converter output terminals. Most units with this feature have two wire remote sensing (output and return) and are limited to 0.5V overall volts drop (0.25V per wire). There is usually a limit on sense lead lengths, typically 1 metre. Because they carry very low currents they are susceptible to noise pick up. It is recommended that they are a twisted pair and if necessary shielded (as shown in Fig. 1).

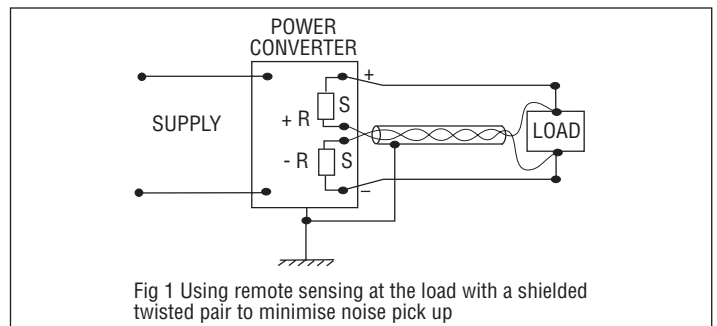

Fig 1 Using remote sensing at the load with a shielded twisted pair to minimise noise pick up

Points worth noting when using remote sensing are:

- The power converter output is running above rated voltage so the maximum current demanded should be reduced from nominal rating to remain within the overall power rating.
- The margin between the output voltage and the over voltage protection trip, if applicable, is lower. Where it is adjustable the OVP trip could be set higher by 0.25 to 0.5V.
- The sense leads are within the feedback loop of the regulating circuit so there may be some deterioration of the dynamic stability of the converter.
- Noise picked up by the sense leads can cause considerable problems.
- Remote sense only operates at the point of connection, so it may not be of much value in systems with distributed loads.
- When the remote sense facility is not used, sense links must be made at the output terminals (there will probably be resistors connected internally to prevent the output voltage from rising excessively if the sense links are left open circuit).

Power Distribution

Daisy Chain

Where multiple loads are connected to a single power converter output, it is always tempting to make "daisy chained" connections to the loads as shown in Fig. 2. The furthest load from the converter will see the lowest voltage and the connecting leads to the nearest load will carry the currents

demanded by all three loads. Since these currents will almost certainly be dynamic this method of connection is a sure recipe for crosstalk.

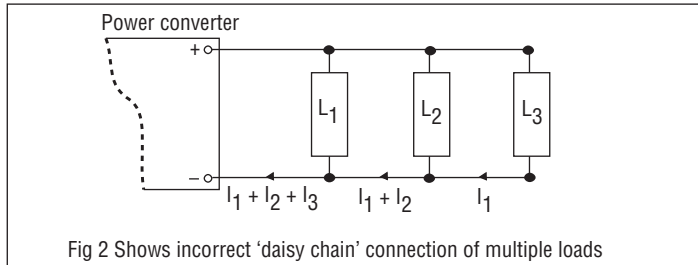

Fig 2 Shows incorrect 'daisy chain' connection of multiple loads

Star Distribution

This is the best method of connecting multiple loads to one output, each load sees the same voltage and no dynamic interference results from combined circulating currents. Sometimes it is difficult to implement this exactly as shown in Fig. 3a, so a compromise solution is shown in Fig. 3b where the wiring from the converter to the star connection points is heavy duty (a copper bus bar in high current systems).

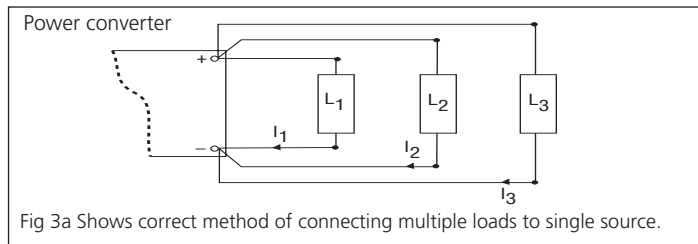

Fig 3a Shows correct method of connecting multiple loads to single source.

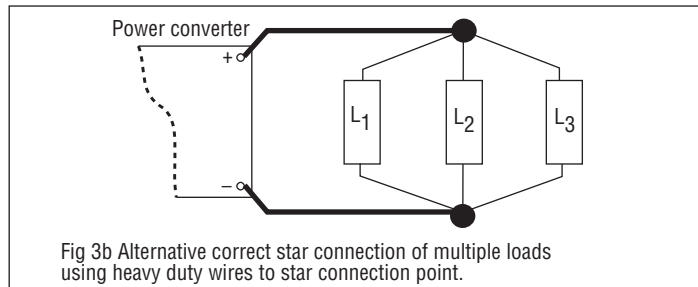

Fig 3b Alternative correct star connection of multiple loads using heavy duty wires to star connection point.

Multiple Outputs

When connecting a number of separate loads to multiple output converters it is advisable to keep each power distribution circuit completely separate. If zero volts returns are combined as shown in Fig. 4a excessive steady state voltage drops may be experienced and dynamic loads can cause crosstalk problems.

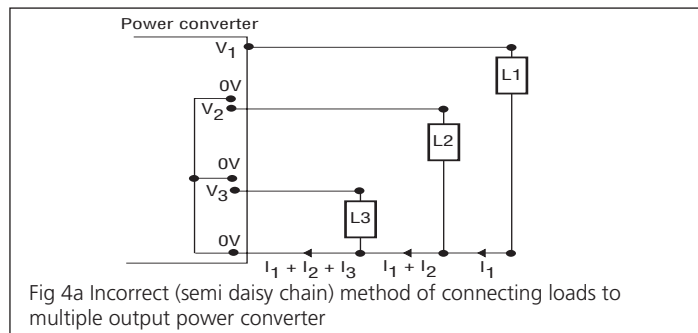

Fig 4a Incorrect (semi daisy chain) method of connecting loads to multiple output power converter

Combined zero volts returns must at all costs be avoided in systems with pulsed loads such as disk drives, printers, CRT displays and magnetic tape decks. Correct connection of such systems is shown in Fig. 4b. Although in

the converter shown the zero volts lines are commoned internally, many power converters have one or more floating (galvanically isolated) outputs. This gives the designer additional flexibility in the design of the system grounding, and polarity choice. For instance it allows analogue and digital power circuits to be kept completely separate with zero volt lines individually connected to a single system earth star point.

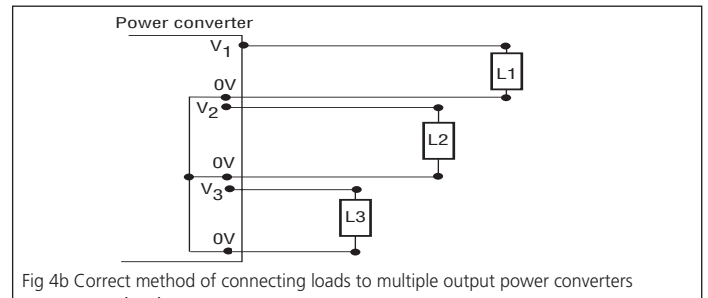

Fig 4b Correct method of connecting loads to multiple output power converters

Load Decoupling

It is impossible to wire the output of a power converter to a load circuit without adding some distributed capacitance and inductance to the output impedance of the converter. If the load demands high speed current pulses as will be the case with most logic systems, there will be resonance effects, and significant voltage spikes will be generated. To prevent false triggering it is necessary to suppress these transients by capacitive decoupling at the load. Suitable for this purpose is an electrolytic capacitor of $1\mu\text{F}$ to $10\mu\text{F}$ in parallel with a high frequency $0.1\mu\text{F}$ ceramic capacitor. It is good practice to individually decouple logic packages and it is often not sufficient to connect the capacitors across the supply lines in the general vicinity of the load. Bypass capacitors should be connected to decouple the current loop by the shortest path possible, direct connection to package pins with the shortest possible lead lengths being ideal.

Operation in Series

Most power converters can be operated in series if they have overload limitation by either constant current or constant power circuits. With some switching converters series operation is prohibited because one unit upsets the feedback regulation system of the other. With linear and switched mode units using foldback current limiting lock out at switch on can occur because of the different ramp up times of two units in series. Care must be taken not to exceed the safe working voltage at the outputs of converters in series. This may be considerably lower than the dielectric strength test voltage which is a short term test between outputs and ground. The output ripple of converters in series is additive but this of course does not change the value of ripple expressed as a percentage of total output voltage. To protect each output from the reverse voltage applied by the other unit in the event of load short circuits, reverse biased diodes are used as shown in Fig. 5. It is common practice to include these protection diodes in laboratory power supplies.

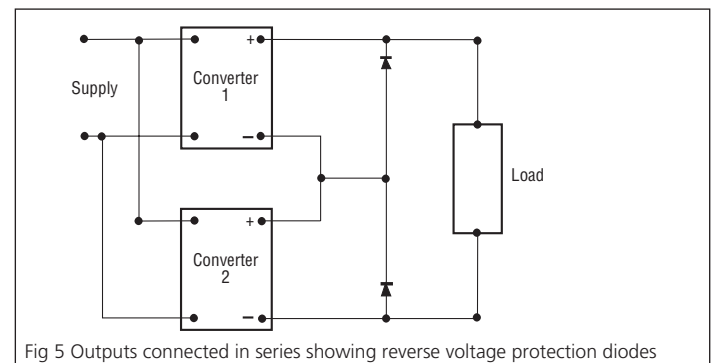

Fig 5 Outputs connected in series showing reverse voltage protection diodes

Operation in Parallel

This is only recommended with power converters specifically designed for parallel connection. A general comment is that it is much lower cost and causes far fewer problems to use a single power converter correctly rated for the application rather than two or more in parallel. However, there are power converters which feature master slave parallel operation. These units are intended for modular expansion schemes and fault tolerant parallel redundant power systems. Where power converters are overload protected by constant current limiting simple paralleling of the outputs can work to an acceptable standard. Output voltages must be set to equality as precisely as possible.

The 15 turn potentiometers on some of the DC/DC converters marketed by Powerbox are ideal for this purpose. In a two unit system the unit with the slightly higher output voltage will reach its current limit and the voltage will drop to equal that of the other unit. This converter will then supply the remaining current demanded by the load. So regulation can never be better than the difference between the output voltage settings of the two converters, and one unit will always be operating in current limit, therefore above its rating. Where current limits are adjustable to below maximum rating simple paralleling is satisfactory if the degradation of regulation can be tolerated.

To improve load current sharing precisely equal series resistors can be used as shown in Fig. 6.

For the best results the wiring resistance must also be exactly balanced. Small differences in the output voltage settings of the converter outputs still creates considerable current unbalance. In the example illustrated (Fig. 6), the load is 5V at 2A. Converter output voltage settings are 5V and if they are unequal by 0.1V, the current out of balance from the nominal 1A is $\pm 0.5A$. This requires that each unit individually rated at 1.5A. It is clearly not a cost effective method of providing 5V 2A of stabilised power. Also note that the 100mW series resistors degrade the regulation to worse than 2%.

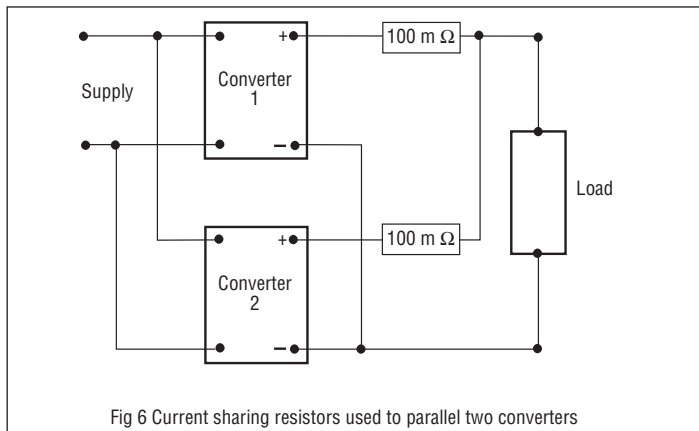

Fig 6 Current sharing resistors used to parallel two converters

Fault Tolerant Power Systems

In critical applications where continuous operation is essential, parallel redundant power systems are often specified. The system has to keep running even when a power unit fails. Current sharing is not such an important criterion since each power unit must be rated to supply the total load. But to enable both units to be continuously monitored for faults it is advisable that some measure of current sharing takes place. Both units are then always operating. Isolating series diodes which are continuously rated at the full load current allow either power converter to continue operation unaffected by a fault in the other. Matching the forward resistance of the diodes and balancing the wiring resistance helps with the current sharing. However, these series impedances degrade the regulation. Some power converters, which are specifically designed for use in fault tolerant systems allow remote sensing downstream of the paralleling diodes to maintain full regulation at the load. In the parallel redundant scheme illustrated in Fig. 7 one of the power converters could be replaced by a battery, or a battery followed by a DC/DC converter to provide a no-break power system in the event of main supply failure.

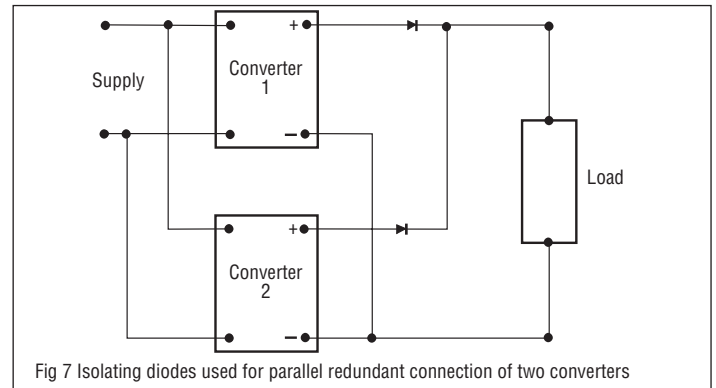

Fig 7 Isolating diodes used for parallel redundant connection of two converters

Thermal considerations

The size of power converters has been reduced quite dramatically since the first commercial switched mode converters became available about 20 years ago. At that time a typical target benchmark for power density (output power/volume) was 60 Watts per litre (1 watt per cu.in.) Today converters operating at three times that power density are relatively common, and some advanced technology DC-DC converters are designed to operate at more than ten times that early benchmark. Efficiency has improved, but has not kept pace with the reduction in volume. Whereas efficiency was typically 65% to 70% it is now 75% to 90%. A useful comparison is the heat to be dissipated per litre from a 67.5% efficient converter with 60 watts/litre output and a 72.5% efficient converter with 180 watts/litre output power. The heat to be expelled per litre goes up from 29 watts to 68 watts.

In fact to bring the internal heat losses down to 29 watts for each litre of volume, the efficiency of the 180 watts/litre (3 watts per cu.in.) converter would have to be 86%.

In the early days of switched mode converters it was thought that 60 watts/litre was about the maximum power density possible for convection cooling. Taking the same "rule of thumb" for 180 watts/litre converters, forced cooling is needed if the operating efficiency is less than 86%.

This does not apply to converters designed for military applications where complex internal structures are used to conduct heat away from all internal components, and the components are specified for higher operating temperatures. Also encapsulated converters, where the encapsulant has good thermal conductivity, and the high heat dissipating components are bonded to a high conductivity substrate do not obey the same "rule of thumb". It is usually important that such converters are adequately bonded to external cold plates or heatsinks to keep their surface temperatures within specification.

Temperature and Reliability

Operation at too high a temperature is the major cause of unreliability in power converters and it is absolutely vital that the user ensures that positive steps are taken to remove the heat lost in the converter so that the immediate environment around it does not exceed the specified maximum operating temperature.

As power converters get smaller more emphasis must be placed on cooling requirements. The heat lost in the converter will not be absorbed internally! Getting rid of 60 watts from a litre of volume needs some help! The best possible help is moving air. Where convected cooling is specified, plenty of space must be allowed for convected action to take place. If in doubt, use forced air. Even a relatively gentle breeze disperses internal hot air pockets and has a very beneficial effect on internal operating temperatures and therefore component life. Every 10°C increase in operating temperature halves expected life.

It is essential to be sure what manufacturers specifications mean when temperature operating range is specified. Is it case temperature range or ambient surrounding air? It is generally better to take the conservative view and assume that it is case temperature. If this is unsatisfactory, clarification should be sought from the manufacturer.

Introduction

There are many national and international standards which deal with the safety aspects of electrical and electronic products. These standards aim to ensure that products are designed, manufactured and tested to eliminate hazards, so that users get equipment which can be installed and used with complete safety. They are intended to prevent injury and damage to persons and property from such hazards as electric shock, fire, dangerous temperatures and mechanical instability. The standards are of particular importance to designers and users of power conversion products. Power converters, especially mains operated power supplies often contain the only barrier separating secondary circuits and accessible metal parts from dangerous AC mains voltages. Furthermore they contain components intentionally designed to dissipate heat which may give rise to high temperature risks.

Applicable Safety Standards

Most industrialised countries published their own safety standards for electrical and electronic equipment. Many of these were based upon IEC recommended standards, but national modifications and variations dependent on end use caused almost insurmountable problems to organisations designing and distributing standard catalogue products in international markets. However, most of these standards were only recommended guidelines and did not have the backing of legislation. In recent years, safety issues have become important politically, and in many countries laws have been enacted to empower enforcement of recognised standards. The reluctance of National Standards Authorities and designated test laboratories to recognise the validity of standards and tests carried out elsewhere has resulted in expensive and time consuming approval programmes. Often six or more separate, but very similar comprehensive safety test programmes have to be carried out on the same product or equipment to obtain safety marking for the main world markets for information technology equipment (ITE) and telecoms equipment (TE). This unsatisfactory situation is gradually being improved, but by no means resolved, by international harmonisation of standards and mutual recognition of test laboratories.

Harmonisation and IEC950

Considerable progress towards an internationally harmonised approach to safety has now been achieved largely due to efforts within the member states of the EU to comply with the Low Voltage Directive (LVD) backed up by work carried out by IEC and CENELEC in the production and promotion of unified standards. The current position is that a single standard, IEC950 is now the predominant safety standard for many electrical and electronic products, including component power supplies.

IEC 950 was first published in 1986, entitled "Safety of Information Technology Equipment" including Electrical Business Equipment. In effect it brought IEC380 (office machines) and IEC435 (data processing) into a single standard. CENELEC adopted IEC 950 and with minimal changes to the text published it with the same title as the IEC document as EN60950.

Brussels based CENELEC comprises the electrotechnical committees of each country within the EU, plus Norway, Switzerland and Iceland, and is responsible for issuing European Norms (EN's). With regard to EN60950, by the 1st March 1991 CENELEC member countries were bound to withdraw conflicting existing standards and publish new harmonised national standards. For instance, in the UK, BS5850 and BS6204 were withdrawn and a new unified standard BS7002 (EN60950) published to replace them. CENELEC has also sponsored moves for mutual recognition of test data produced by officially recognised authorities within member states. CECC marked components are now well established with reciprocal recognition within Austria (OVE), Belgium (CEBEC), Denmark (DEMKO), Finland (SETI), France (UTE), Germany (VDE), Ireland (IIRS), Italy (IMQ), Netherlands (KEMA), Norway (NEMKO), Spain (IRANOR), Sweden (SEMKO), United Kingdom (BS). With respect to component power supplies, the mark of a national test organisation from any one of these countries showing compliance with

EN60950, should be sufficient proof of compliance in any other country.

The IEC (International Electrotechnical Commission) is a voluntary body with worldwide recognition. It is Geneva based and now has more than 40 countries worldwide as participating members, including the USA and Canada. It has been setting recommended standards for electrical equipment for worldwide use for many years.

IECEE CB scheme is an international system based on international IEC standards and national differences of member countries. CB test reports issued by certification organizations are accepted by member countries and no additional testing is required.

Relevant EC Directive

Directive 72/23/EEC, the Low Voltage Directive (LVD) was published to provide a common set of basic rules for the safety of electrical equipment throughout the EU, and to thereby promote freedom of trade for such goods within the EU. It covers with minor exceptions all equipment operating over 50V to 1000VAC and 75V to 1500VDC.

To demonstrate compliance with the directive, testing to the relevant EN is required and then: either

- a) a recognised mark affixed
 - or b) a certificate of conformity supplied
 - or c) a manufacturer's statement of conformity supplied
- a) and b) are obtainable from recognised national test authorities such as SEMKO, VDE, BS etc.*

The official publishing and implementation within the EU of the CE marking Directive 93/68/EEC makes clear that the provisions of this directive, originally intended to apply to "New Approach Directives" have been extended to one "Old Approach Directive", the LVD. All products and equipment which are covered by the LVD must then be CE marked to be legally sold within the EU. CE marking implies compliance with all relevant directives. Many component power supplies are open frame units with no user protection against contact with live parts. They can only be regarded as fully satisfying the LVD when assessed in situ within the final host equipment. They should be supplied together with a warning notice which could be worded as follows: "Although CE marked in accordance with the LVD, these units are intended for use only within other equipment. The final equipment manufacturer is responsible for protection against contact with hazardous live parts".

EN60950

Latest edition of this standard is EN60950-1 and equivalent UL standards is UL60950-1.

Because a very large proportion of power converters have their end use in information technology equipment and electrical business machines, and because the standard must attain the status of a regulation in member countries, it has become accepted as the most important safety standard for power conversion equipment.

Hazards

EN60950 introduces the principles of safety and defines the hazards with which it is concerned, these being

- Electric shock
- Energy hazard
- Fire
- Mechanical and heat hazards
- Radiation hazards
- Chemical hazards

Application

Application of the standard is wide. It is applicable to information technology equipment, including electrical business equipment and associated equipment with a rated voltage not exceeding 600V. It is intended to ensure the safety of operators, members of the public and service personnel.

Classes of Equipment

Classes I, II and III are defined:

Class I equipment

Electric shock protection is achieved by

- a) basic insulation
- and b) protective earth

All conductive parts which could assume hazardous voltages in the event of failure of basic insulation must be connected to a valid protective earth conductor.

Class II equipment

There is no provision for protective earthing and electric shock protection is by double insulation or reinforced insulation.

Class III equipment

Protection against electric shock relies on supply from SELV circuits and it is impossible for hazardous voltages to be generated within the equipment.

Definitions

There are many definitions contained in the standard, some of these with great relevance to power converter designers and users are:

i) Hazardous voltage

A voltage exceeding 42.2V peak or 60VDC in a circuit which does not meet the requirements for a limited current circuit.

ii) Extra-low voltage (ELV)

A voltage in a secondary circuit not exceeding 42.4 V peak or 60VDC, the circuit being separated from hazardous voltage by at least basic insulation.

iii) Safety extra-low voltage (SELV) circuit

A secondary circuit that under normal operation or a single fault condition cannot reach a hazardous voltage between any two accessible parts or an accessible part and protective earth. In the event of a single fault condition (insulation or component failure) the voltage in accessible parts of SELV circuits shall not exceed 42.4V peak or 60VDC for longer than 0.2 s. Also an absolute limit of 71V peak or 120VDC must not be exceeded.

SELV circuits must be separated from hazardous voltages (e.g. primary circuits) by two levels of protection which may be double insulation, or basic insulation combined with an earthed conductive barrier. The importance of power supply SELV secondaries is that they are considered safe for operator access. Also circuits fed by SELV power supply outputs do not require extensive safety testing or creepage and clearance evaluations in approval test programmes.

iv) Limited current circuits

These circuits may be accessible even though voltages are in excess of SELV requirements. A limited current circuit is designed and protected so that under a likely fault condition, the current which can be drawn is not hazardous. Limits are detailed as follows:

- a) For frequencies not in excess of 1 kHz the steady state current drawn through a 2000Ω non-inductive resistor connected between an accessible part of the circuit and either pole of that circuit or earth shall not exceed 0.7 mA peak AC or 2 mA DC. For frequencies above 1 kHz the limit of 0.7 mA is multiplied by the frequency in kHz but shall not exceed 70 mA.
- b) For accessible parts not exceeding 450 V peak or DC, the maximum circuit capacitance allowed is 0.1 μF.
- c) For accessible parts not exceeding 15000V peak or DC the maximum stored charge allowed is 45μC and the available energy shall not be above 350 mJ.

To qualify for limited current status the circuit must also have the same segregation rules as SELV circuits.

Protective Earth

Class I equipment must have a protective earthing conductor which may be bare wire or insulated. If insulated it must be green/yellow or transparent

covering. No switch or fuse is allowed. Resistance between earthed parts and the earthing termination must not exceed 0.1Ω. This is tested by a current 1.5 times the current capacity of any hazardous voltage circuit at the point where failure of basic insulation would make the earthed part live. Test voltage maximum is 12V. Test current may be AC or DC but must not exceed 25 A.

Clearances required for insulation

Clearances between primary and secondary circuits and for isolation in primary circuits depend on working voltages and the degree of pollution of the operating environment. Power converters which are intended for general application should be designed for worst case conditions (pollution degree 3 and mains voltages to 264 AC).

From the table published in the standard it can be deduced that the minimum clearances are as follows:

- 4.00 mm for reinforced or double insulation
 - 2.00 mm for basic and supplementary insulation
- (table is valid for installation class II)

Where a formal manufacturing quality control programme is in place relaxation to 3.4 mm and 1.7 mm is allowed, but reinforced insulation is then subjected to 100% electric strength testing. If an air gap serves as reinforced insulation between a hazardous voltage and an accessible conductive part of the enclosure of floor standing equipment or the non-vertical surface of desk top equipment the required clearance is 10 mm.

Creepage distances

Tables of creepage distances for basic insulation are given for various pollution conditions and materials, the distances depending on working voltages. These distances are doubled for reinforced insulation.

Power cords and connectors

Mechanical strength and electrical requirements are dealt with in depth. An important table for power converters which are connected to mains power via studs or screw terminals is the table of terminal sizes reproduced below

Rated current A	Minimum nominal thread dia mm	
	Pillar or stud type	Screw type
≤10	3.0	3.5
10-16	3.5	4.0
16-25	4.0	5.0
25-32	4.0	5.0
32-40	5.0	5.0
40-63	6.0	6.0

Flammability

The standard requires that the equipment design

- a) avoids high temperatures, or shields and separates flammable materials from high temperature parts
- b) uses materials of low flammability both internally and for enclosures
- c) uses fire enclosures to limit the spread of fire

Compliance can be achieved by using V-2 or better rated, insulating and printed board materials throughout and ensuring adequate spacing between high temperature components and plastic and painted parts. Even better, use UL listed materials and the necessity for exhaustive and messy flammability testing is removed.

Earth Leakage Current

For Class II equipment this shall not exceed 0.25 mA, for hand held Class I equipment 0.75 mA, and other Class I equipment 3.5 mA.

The test for Class II equipment requires conductive metal foil to be attached to an area not exceeding 10 x 20 cm on accessible non-conductive parts and the test is made between this and conductive parts. Tests are carried out at the most unfavourable (highest possible) supply voltage.

Electric strength test voltages

Insulation between circuits is tested using a sinewave voltage at 50/60 Hz or a DC voltage equal to the peak voltage of the prescribed AC test voltage, applied for 1 (one) minute without breakdown.

For common peak working voltages (maximum of input voltage + internal generated peak voltages) the rms AC test voltages for primary to body, primary to secondary and between parts in primary circuits are as follows:

Insulation	<184V peak working	184V <354V peak working
Basic	1000Vrms	1500Vrms
Reinforced	2000Vrms	3000Vrms

No test is required from secondary to body if the secondary voltage is less than or equal to 60VDC or 42.4V peak. For higher voltages a table of test values is given in the standard.

User Instructions and Labelling of Equipment

Labelling of equipment is covered in detail including the correct display of rating data and any important safety warnings. Where symbols are used these must conform to ISO standard 7001 and IEC publication 417. Installation and operating instructions must be made available as should any special safety instructions needed to avoid hazards when operating, installing, maintaining, transporting or storing equipment.

Stability and Mechanical Hazards

Equipment should be able to safely survive a tilt of 10° in any direction and return to an upright position. Floorstanding equipment (e.g. UPS) should withstand forces equal to 20% of total weight (to a maximum of 250 Newtons) applied in any direction except vertically, at any height up to 2m. Equipment should operate safely when tilted continuously up to 5° from the normal position.

Telecommunications Safety Standards

Providers of telecommunication services have particular safety concerns:

- Safety of service personnel working on the network ensuring that the network cannot become energised by hazardous voltages emanating from equipment connected to the network.
- Conversely ensuring that users of equipment connected to the network are properly isolated from voltages on the network.

These particular concerns have been addressed in the UK by safety standard BS6301, which has been used as the basis for obtaining BABT approval (British Approvals Board for Telecommunications).

The EU has adopted EN60950 as the core safety standard for telecommunications equipment. This is supplemented with EN41003 "Particular Safety Requirements for Equipment to be connected to Telecommunications Networks". Following the publication of edition 2 of IEC950 the EU has issued an updated version of EN60950 which incorporates EN41003 as clause 6.

This introduces the concept of a TNV (Telecommunications Network Voltage) circuit which is defined as "A circuit which under normal operating conditions carries telecommunications signals". TNV circuits are treated as additional secondary circuits that must be isolated from "Excessive Voltages" by one of

- double or reinforced insulation
- basic insulation with protective earthed screen
- basic insulation with protective circuitry (e.g. fuses and MOVs).

Excessive voltages are defined as voltages not normally found on telecommunication networks and where:

$V_{ac}/70.7 + V_{dc}/120 > 1$, V_{ac} and V_{dc} being maximum voltage deviations under worst case conditions (EN 60950 section 1.4). TNV circuits require only basic insulation for isolation from SELV circuits. Where SELV circuits are earthed TNV circuits may be directly connected.

Medical

In the EU, technical safety problems of Electromedical Equipment are addressed by the EN60601 series of standards which follow IEC 60601. In the USA, UL544 covers medical and dental equipment, but in 1994 UL2601-1

came into effect. This standard is harmonised with IEC 60601-1.

A power supply approved to IEC 60950 (EN60950) would need to pass additional tests to meet the requirements of EN60601-1 for separation, leakage, dielectric strength and isolation transformer construction to enable its use in medical equipment. The "Y" capacitors required in the input filter of a standard ITE switched mode power supply would almost certainly cause the power unit to fail on the grounds of excessive leakage current. Briefly, the more stringent requirements which are of particular relevance to power supplies are:

- Mains to secondary creepage and clearance distances for double or reinforced insulation for equipment operating up to 250VAC (over the isolation barrier) maximum must be 8mm and 4mm respectively.
- Primary to secondary dielectric withstand test must be 4000VAC.
- Earth leakage current maximum is 0.5mA (0.3mA for UL60601-1) for normal operation and 1mA maximum for a single fault condition. These values are for type B, type BF and type CF equipment categories.

<i>type B (Body)</i>	<i>Non-patient equipment, or equipment with grounded patient connection.</i>
<i>type BF (Body Floating)</i>	<i>Equipment with a floating patient connection</i>
<i>type CF (Cardiac Floating)</i>	<i>Equipment with a floating connection for direct cardiac application</i>
- Patient leakage current for the above categories is 0.1mA (0.5mA single fault) for type B and BF and 0.01mA AC (0.05mA @ single fault) for type B and BF and 0.01mA AC (0.05mA @ single fault) for type CF. For DC leakage current the values are 0.01mA DC (0.05mA DC) for all protection.

Safety Testing

Power converters supplied by Powerbox have been tested by the manufacturers to the relevant standards.

Customers need not, and should not carry out safety testing on units supplied by Powerbox, especially where a properly designed safety test fixture is not available. Such a test fixture should have an operator's shield with a high voltage disable safety interlock to protect personnel from danger.

Manufacturers Test

For AC operated power supplies, 100% of converter transformers, and other devices coupling primary and secondary circuits, such as feedback transformers and opto couplers, are subjected to safety testing. This is normally 3750V RMS primary to all secondaries for 1 minute without breakdown or flashover.

Complete power units are usually type tested to the same level but with the "Y" capacitors removed from the input line filter.

The test voltage normally used as a final high voltage flash test to prove the safety integrity of fully assembled power supplies is 1500V RMS. This is applied between AC inputs and all outputs connected together and to ground. A functional test follows to check that no circuit components have been damaged.

Warnings

Removal of the "Y" capacitors by customers to carry out high voltage safety tests invalidates the warranty.

Input/output isolation tests carried out on switched mode power supplies without grounding the outputs are usually disastrous! Division of the test voltage by capacitances to ground applies almost all of the test voltage between output and ground so damaging secondary components. Isolation (high pot) tests on complete systems with power units in place can cause similar damage. Therefore such tests should be carried out with the power units removed or with all power unit outputs strapped to earth. Units which have been damaged in this way are not covered by the warranty.

Introduction

As a result of the vast increase in the use of information technology and communications equipment, and of domestic and industrial electronics, the electromagnetic environment is suffering extreme pollution. By the early 1980s West Germany (FTZ) and the USA (FCC) recognised the seriousness of the problem and introduced regulations limiting interference emissions from commercial and industrial products. Also, the International Special Committee on Radio Interference (CISPR), originally set up in 1934 to concentrate on test methods, began to issue recommendations and standards. Most other developed countries issued national standards based on CISPR recommendations but these standards did not have the force of law.

EU Directive

A major move towards minimising "pollution of the air waves" was taken in the European Community in 1989 by the publishing of the EMC Directive 89/336/EEC. This Directive requires harmonization of EMC requirements throughout the Community and requires Member States to introduce local laws to enforce appropriate regulations. It requires that apparatus does not generate excessive electromagnetic disturbance levels that would interfere with the proper functioning of other apparatus or radio and telecommunications equipment. Also apparatus must have adequate levels of intrinsic immunity to electromagnetic disturbances to enable it to operate as intended. The Directive is therefore concerned with both the generation of, and the susceptibility to, interference from electromagnetic and radio noise.

Transitional period

Originally it was intended that Member States standards would be harmonized, and have the backing of national laws by 1st January 1992 to coincide with the commencement of the Single European Market. Where standards were not in place there was to be a one year transitional period, i.e. to 1st January 1993 during which time existing standards could be used. However this timescale proved impractical so an Amending Directive 92/31/EEC was issued to allow an extended transitional period. Until 31st December 1995 Member States could authorize the placing on the market/and or putting into service apparatus conforming to the national regulations in force in their territory on 30th June 1992.

Scope of Directive

Any piece of equipment which is liable to cause an electromagnetic disturbance, or be affected by such disturbance is covered. Therefore every apparatus which uses a power converter comes within the scope of the Directive.

There are some specific exclusions from this Directive where reference to EMC requirements form part of another Directive. Some specific instances are *active implantable medical devices (90/385/EEC)*, *other medical devices (93/42/EEC)*, *electrical energy meters (76/891/EEC)*

Components are excluded where 'component' is defined as any item which is used in the composition of an apparatus and which is not itself an apparatus with an intrinsic function intended for the final consumer. Sub-assemblies which are to be tested as part of a larger apparatus are regarded by the Commission as outside the scope of the Directive. With this interpretation it is fair to say that the majority of power converters which are to be used inside other equipment are not in themselves covered by the Directive. However most users will wish to minimise the problems they face with regard to ensuring that their total system or end product meets the requirements, so will insist that purchased sub-assemblies comply with the necessary standards.

TTE Directive (91/263/EEC)

Some overlap exists between this Directive and the EMC Directive. TTE (Telecommunications Terminal Equipment) which is not also classified as a radio transmitter must meet the EMC requirements included in the Common Technical Requirements (CTR) to which the TTE is type approved. For any EMC aspects not covered by the CTR, the equipment must comply with the EMC Directive.

If an apparatus is a TTE and a radio transmitter it is subject to the TTE Directive, the EMC Directive and local National Spectrum Management restrictions.

Relevant standards

The EMC Directive does not contain detailed specifications but refers to relevant standards. These standards are produced by CENELEC, usually following CISPR and IEC guidelines and published in the Official Journal of the European Union.

A recent list of European harmonized standards complying with the essential requirements of the Directive is as follows.

PRODUCT CATEGORY STANDARDS	
European Reference Number	Harmonized Standard and Title
EN55011	CISPR11 (1990) ed 2 - Limits and methods of measurement of radio disturbance characteristics of industrial, scientific and medical (ISM) radio-frequency equipment.
EN55013	CISPR13 (1975) ed 1 + Amdt. 1 (1983) - Limits and methods of measurement of radio disturbance characteristics of broadcast receivers and associated equipment.
EN55014-1	CISPR14 (1985) ed 2 - Limits and methods of measurement of radio interference characteristics of household electrical appliances, portable tools and similar electrical apparatus.
EN55015	CISPR15 (1985) ed 3 - Limits and methods of measurement of radio interference characteristics of fluorescent lamps and luminaires.
EN55020	CISPR20 - Immunity from radio interference of broadcast receivers and associated equipment.
EN55022	CISPR22 (1985) ed 1 - Limits and methods of measurement of radio interference characteristics of information technology equipment.
EN60601-1-2	General requirements for safety. Collateral standard: Electromagnetic compatibility. Requirements and test.

Where Product Standards do not exist Generic Standards may be used. Generic Standards relate to the environmental areas in which the apparatus will be used. Product Standards take precedence over Generic Standards.

European Reference Number	
	Electromagnetic compatibility generic immunity standards
EN61000-6-1	Residential
EN61000-6-2	Industrial
	Electromagnetic compatibility generic emission standards
EN61000-6-3	Residential
EN61000-6-4	Industrial

Demonstration of compliance

Probably the best way to product certification for most electronic products and systems is by demonstration of compliance with the appropriate standards. All equipment need an EU certificate of conformity, certifying that it meets the requirements of the Directive. All separable parts of equipment, all apparatus and products have to carry an EU conformity mark consisting of the letters 'CE'. A statement of conformity must accompany each piece of apparatus which must properly identify the product category and the relevant standard, and name the signatory empowered to legally bind the manufacturer or his EU agent. This is in effect self certification by the manufacturer.

N.B.

This route to certification cannot be used for radio and telecommunications equipment. Apparatus in these categories can only be certified by an accredited test house.

Technical File

Another route towards certification is by raising a special technical file. This is mainly for special equipment categories where it is thought that current standards are either non-existent or inappropriate. The technical file must contain:

- (i) The equipment identification.
- (ii) A description of the procedures used to ensure conformity with the Directive.
- (iii) A technical report and certificate from a recognised assessment authority.

Emission Standards

High Frequency Emission Standards

There are two types of HF emission with which these standards are concerned, mains terminal interference voltages (line conducted interference) and radiated interference field strengths. There are also two different sets of limits, one for class A equipment, and the other, more stringent for class B equipment. In general class A equipment is restricted to use in industrial or other specially designated environments. In Germany such equipment needs a special operating licence. This has to be obtained from the FTZ (Federal Telecommunications Agency) and will only be issued for fixed installations in designated industrial zones. Class B equipment is not subject to restrictions and may be used in residential, office, hospital and telecommunications environments.

Power conversion product manufacturers and users are mainly concerned with the following standards.

EN55022 (CISPR22) European Standard for Information Technology Equipment (ITE)

FCC part 15 sub part J U.S.A. standard for ITE

Limits for Mains Terminal Interference

FCC class A and class B limits cover the frequency spectrum from 450 kHz to 30 MHz, and as can be seen from Fig 8 the requirements are less stringent.

Limits for Radiated Interference

The standards for radiated limits are shown in Fig 9 (a) and Fig 9 (b). These are more difficult to compare than the conducted interference limits because different test distances are nominated in different standards.

Fig 9 (a) shows EN55022. The EN55022 specification is relatively simple with no requirements below 30 MHz, and the difference between class A and class B being different measurement distances, 30 m and 10 m respectively.

Fig 9 (b) shows the limits for FCC part 15 compliance. Like EN55022 there are no requirements below 30 MHz. Class A limits are very similar to those in EN55022 although more difficult to compare, because of different measuring distances. It is fair to say that equipment meeting EN55022 class B will also meet FCC class B requirements.

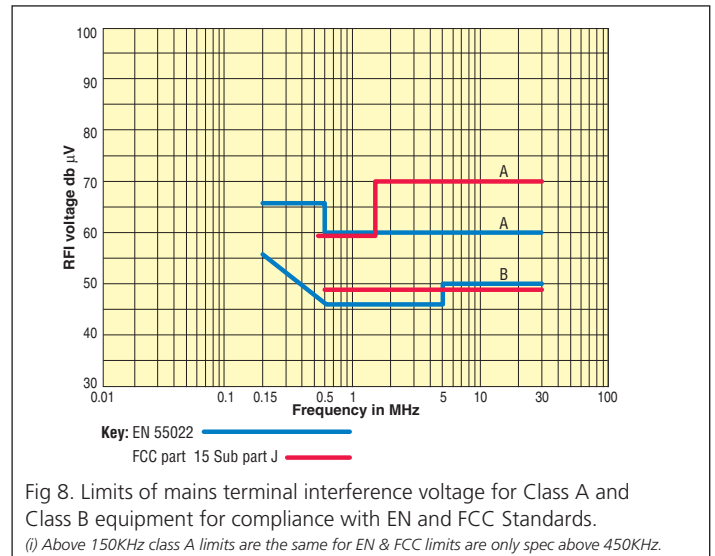

Fig 8. Limits of mains terminal interference voltage for Class A and Class B equipment for compliance with EN and FCC Standards.

(i) Above 150KHz class A limits are the same for EN & FCC limits are only spec above 450KHz.

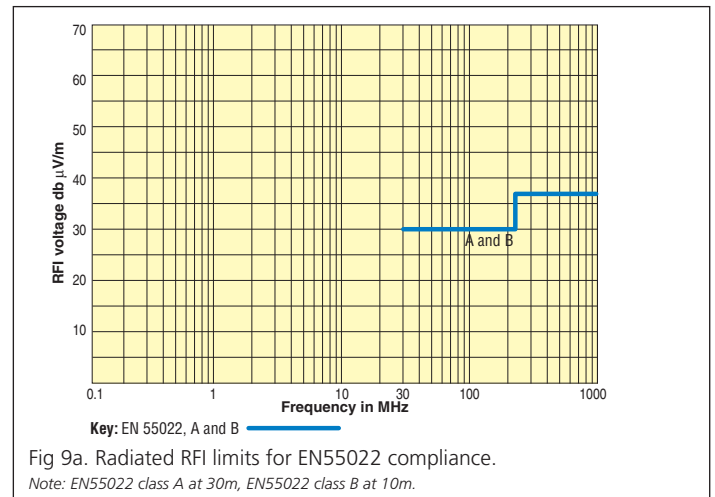

Fig 9a. Radiated RFI limits for EN55022 compliance.

Note: EN55022 class A at 30m, EN55022 class B at 10m.

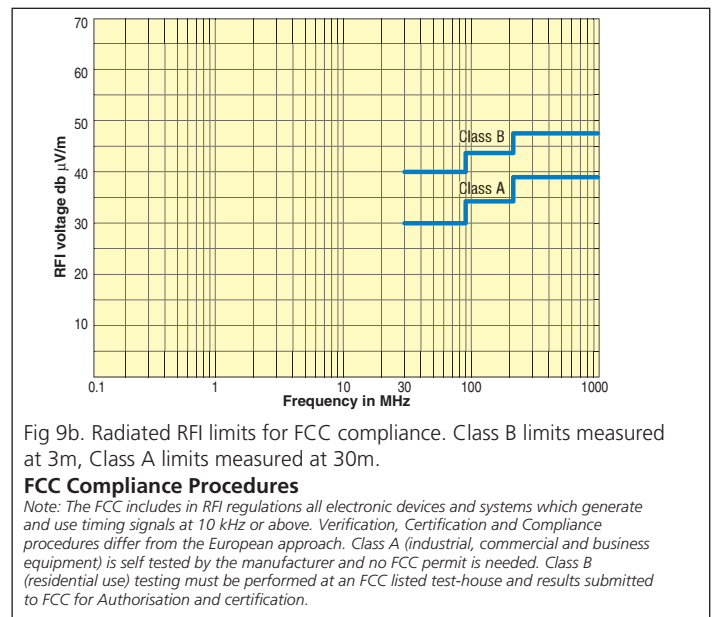

Fig 9b. Radiated RFI limits for FCC compliance. Class B limits measured at 3m, Class A limits measured at 30m.

FCC Compliance Procedures

Note: The FCC includes in RFI regulations all electronic devices and systems which generate and use timing signals at 10 kHz or above. Verification, Certification and Compliance procedures differ from the European approach. Class A (industrial, commercial and business equipment) is self tested by the manufacturer and no FCC permit is needed. Class B (residential use) testing must be performed at an FCC listed test-house and results submitted to FCC for Authorisation and certification.

Low frequency Emission Standards

Harmonics

The product category standards listed in the table in the section "Relevant standards" shows EN60555-2 as applied to household appliances and similar electrical equipment. This standard is superseded by EN61000-3-2 which covers all electrical equipment connected to AC mains supplies, and drawing up to 16A input current. CENELEC has used IEC1000-3-2 as the basic document for EN61000-3-2.

In this standard equipment is classified into 4 different groups as follows:

Class A	Balanced 3 phase equipment and all equipment not in one of the other 3 classes
Class B	Portable tools
Class C	Lighting equipment including discharge lamp dimmers
Class D	Equipment up to 600W input power having a special waveshape

The diagram in Fig 10a shows the definition of special waveshape for the class D category. Equipment is in class D if the input current waveform is in the shaded zone for at least 95% of each half period. The actual limits allowed for odd harmonics for the four classes are listed in the following table.

Harmonic n	Class A Amps	Class B Amps	Class C Amplitude Ratio %	Class D mA/W
1	-	-	-	-
3	2.30	3.45	30I	3.4
5	1.14	1.71	10	1.9
7	0.77	1.155	7	1.0
9	0.40	0.60	5	0.5
11	0.33	0.495	3	0.35
13	0.21	0.315	3	0.30
15+	2.25/n	3.375/n	3	3.85/n

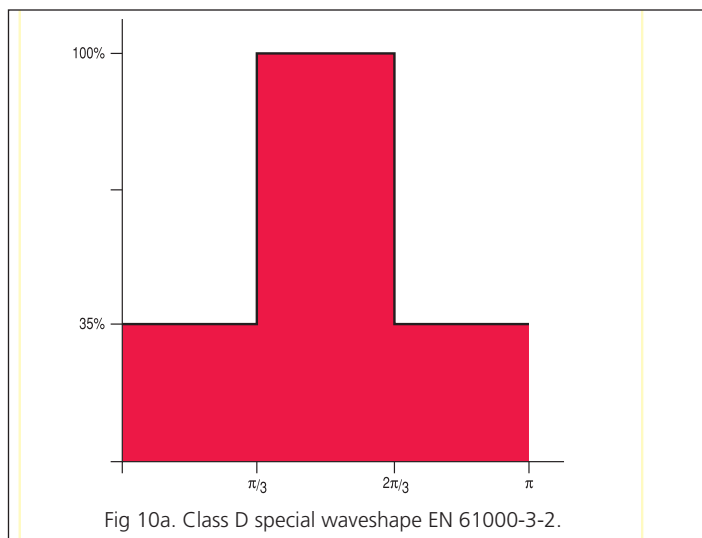

Fig 10a. Class D special waveshape EN 61000-3-2.

Harmonic limits EN 61000-3-2 Odd harmonics

Notes: 1 Below 75W no limits apply. This reduces to 50W by 5th July 1988.

2 Class A/B limits are absolute

3 Class C/D limits are proportional

4 Class D limits apply up to 600W, thereafter Class A limits apply

5 Above 1000W no limits apply for professional equipment

6 No limits apply to light dimmers up to 1000W

7 I is the power factor defined as

$$I = \frac{\text{real input power}}{\text{input VA}}$$

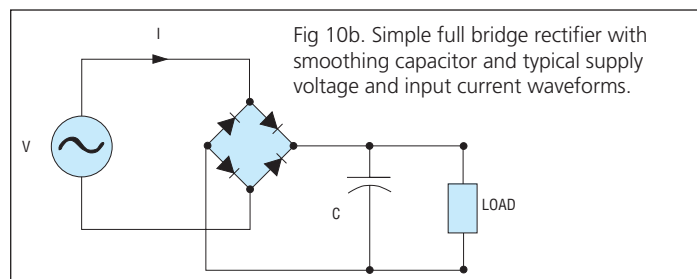

Fig 10b. Simple full bridge rectifier with smoothing capacitor and typical supply voltage and input current waveforms.

Fig 11 shows the input current waveform of a typical direct off the line full bridge rectifier with capacitor smoothing (the normal input circuit of an SMPS). Current only flows to charge the capacitor when the rectified input voltage exceeds the voltage stored. Circuit resistance is very low, only the ESR of the capacitor and forward resistance of the rectifier, so current rises very rapidly. Pulses of current with a very high odd harmonic content are drawn from the supply near each peak of the voltage waveform. The larger the stored energy in the capacitor relative to the continuous power, the shorter and peak are the current pulses. Power supplies designed for long hold-up times, and power supplies used at a low fraction of their rated power therefore have higher harmonic content (and lower power factor). The waveforms shown in Fig 11 are idealised. In a real circuit, because of finite source and circuit impedances the voltage waveform would be flat topped and the current pulses may be slightly skewed.

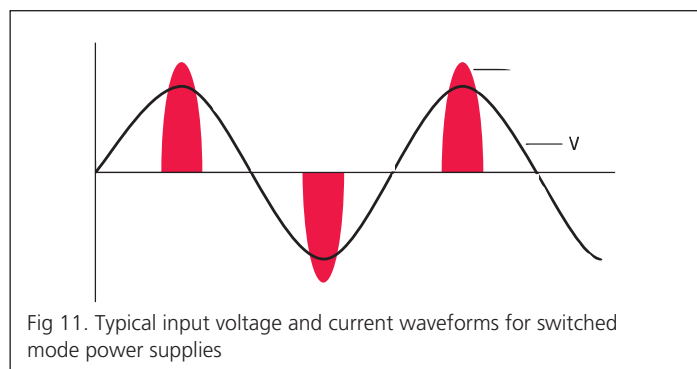

Fig 11. Typical input voltage and current waveforms for switched mode power supplies

Without some form of input waveform correction SMPS fall into class D, (class D only applies up to 600W input power, thereafter class A limits apply). Adequate correction can be achieved by using a series inductor to spread the current waveform sufficiently to move from class D to A. At low power the absolute limits of class A are much easier to meet than the relative limits of D. Above 600W, the absolute limits of class A require a filter inductor with as much copper and iron as a mains transformer of similar rating, making weight and volume advantages of SMPS questionable.

Fortunately, active input waveform correcting circuits and integrated circuit control devices are available. One of the most successful schemes uses a high frequency current mode boost preregulator which forces the input current to follow precisely the waveshape of the input voltage. A voltage control loop regulates the DC output voltage of the rectifier to a constant value above the peak of the AC waveform (typically 380-400V). Very low harmonic amplitudes can be achieved with this technique with power factors well above 0.95. One other major advantage is that universal input operation from 85V to 260V is easily obtained. The disadvantages are increased circuit complexity and cost, lower MTBF, increased space requirement, 5% efficiency reduction, and increased RFI generated.

Another scheme which has shown some promise is a hybrid active/passive approach where a series inductor is switched into the input circuit twice per mains cycle to store energy during the first part of each half cycle when the rectifiers are normally non-conducting, then releasing this energy to the capacitor later in the half cycle, this greatly reducing the peak current and

widening the effective conduction angle. This technique uses an inductor less than half the size that a purely passive filter would need, and has successfully achieved power factor in excess of 0.9.

Linear power supplies with capacitor smoothing also have problems meeting the standard. Although the leakage inductance of the mains transformer is helpful, additional series inductance is normally required.

Voltage fluctuations

The standard EN61000-3-3 limits the disturbances on supply systems caused by household appliances and other domestic electrical and electronic equipment. This EN applies to all electrical equipment up to 16A input current, and has a similar calendar of implementation to EN61000-3-2. It is not thought to have significant implications for the design and utilisation of electronic power conversion equipment.

Immunity standards

The majority of users and designers of electronic equipment are familiar with malfunctions caused by susceptibility to electromagnetic disturbances, but unfamiliar with standards specifying immunity levels to ensure proper operation of equipment. This is largely because such official standards are a rarity. For specific applications designers and installers of electronic equipment have successfully dealt with such problems as mains sags and surges, electrostatic discharge, lightning strikes, RFI etc. The initiative to solve these problems has been customer or situation led, rather than an attempt to meet a recognised standard. Now, with the EMC Directive, at least within the EU this approach is no longer acceptable.

IEC801

The attempt to assess equipment immunity arose initially to safeguard the reliable operation of industrial process control equipment. This led to the publication of IEC801, defining susceptibility limits and test methods. Subsequently IEC801 has been expanded in scope, now being applied to a much wider range of electronic equipment than was first envisaged. The first products to be covered were those associated with legally enforceable metering such as petrol pumps and automatic weighing machines. Subsequently domestic electronic equipment, radio and TV receivers came within its scope. The EMC directive now spreads the net wide and brings in virtually all electronic equipment.

The problems addressed in the original publication were electrostatic discharge, RF radio transmissions and mains transients, and these were dealt with as outlined in the following brief summaries.

IEC801 part 2 defines test and measuring procedures to simulate an operator becoming electrostatically charged (due for instance to moving over a nylon carpet) then discharging into the apparatus via accessible metalwork.

Test levels from 2 kV to 15 kV are recommended, the level used being dependent on the relative humidity and the extent of the use of man-made fibres in the vicinity of the installation.

IEC801 part 3 covers immunity to RF transmission in the band 27-500 MHz (walkie-talkie and private mobile radio bands). The equipment being tested is subjected to the RF field between a parallel plate transmission line (terminated with its characteristic impedance). An appropriate input power is applied to give the correct level of field strength and the frequency is then swept from 27-500 MHz.

IEC801 part 4. This section is of immediate importance to power conversion equipment because it is concerned with immunity to short duration mains transients. The characteristics of the transients to be applied are as follows:

- risetime 5 ns +30%
- duration 50 ns +30%
- burst duration 15 ms
- burst period 300 ms

The repetition frequency of the transients within the 15 ms burst zone is 5 kHz for transient amplitudes up to 1 kV and 2.5 kHz for transients of 2 kV and above. Transients are applied for a 1 minute period with no damage or malfunction of the equipment being tested.

EN standards

The above immunity specifications (IEC801) were the basis of the first generic immunity standard to be published, namely EN50082-1 (1992) covering residential, commercial and light industrial environments. A further two IEC801 documents have been issued, IEC801-5 (AC mains surges) and IEC801-6 (conducted RFI). To fully establish this series as general immunity requirements, rather than specific to process control, the IEC has issued the IEC1000-4 specifications and CENELEC has adopted these as the EN61000-4 series. In some instances where IEC draft documents were not yet issued, CENELEC has created ENV documents for interim use. The current situation is summarised in the following table.

Disturbance	IEC Process	New IEC	CENELEC	
	Control IEC801 series	general IEC1000-4	Interim ENV	EN61000-4
Electrostatic Discharge	801-2	1000-4-2		61000-4-2
Radiated RFI	801-3	1000-4-3	ENV50140	61000-4-3
Fast Transients	801-4	1000-4-4		61000-4-4
Mains Surges	801-5	1000-4-5	ENV50142	61000-4-5
Conducted RFI	801-6	1000-4-6	ENV50141	

In addition to the above

Disturbance	IEC	EN
Mains frequency magnetic field	IEC 1000-4-8	EN61000-4-8
Pulsed magnetic field	IEC 1000-4-9	EN61000-4-9
Damped oscillatory magnetic field	IEC 1000-4-10	EN61000-4-10
Supply voltage dips and interruptions	IEC 1000-4-11	EN61000-4-11

Product Category Standards

At present there are a few product category standards for immunity progressing such as EN55014-2 (household tools, appliances etc, EN50065-2 (signalling on low voltage installations) and EN55024 (information technology equipment. Immunity characteristics. Limits and methods of measurement).

Where there are no product specific standards in place, compliance with the EMC Directive comes under the generic standard. This will be the requirement for the majority of equipment.

- EN61000-6-1 Residential, commercial and light industry
- EN61000-6-2 Industrial

Criteria for compliance

These can vary dependent on the test being carried out and whether a malfunction of the equipment is considered to be safety related. Some tests will therefore require that the equipment operates normally without damage or malfunction during the test procedure. For instance, corruption of software or data in process or memory is deemed a test failure in ITE. For non-safety related functions orderly shutdown and manual reset and re-start is allowed.

Component power supplies

Such power supplies, which do not have an identifiable end use independent of the host equipment, do not come within the scope of the EMC directive as a stand alone sub assembly. CE marking of such sub assemblies will demonstrate only that they meet relevant safety requirements and accord to the LVD. However equipment manufacturers will in many instances be unwilling to make the modifications, extra filtering, shielding, input current waveshaping etc needed to incorporate non-compliant power supplies into equipment for sale in the EU. So component power supplies intended for general use will normally comply to relevant standards.

Medical Equipment

Two New Approach Directions, 90/385/EEC Active Implantable Medical Devices (AIMD) and 93/42/EEC Medical Devices Directive (MDD) exempt those specific product categories from the EMC Directive. They contain their

own specific EMC requirements. Probably only the MDD will be of interest to power conversion designers and users. The EMC standards cited are IEC601-1-2, adopted by CENELEC and published as EN60601-1-2. Emission standards required follows CISPR 11 (EN55011), normally class B, with a 12dB relaxation for radiated emissions in X-ray rooms.

An important point to note for all products subject to the AIMD, and many products under the MDD (except class I). They cannot be self certified. Approvals must be carried out by Notified Test Organisations.

RFI Filtering in Power Supplies

Nearly all switched mode power converters intended for use on mains supplies are filtered to be compliant with either level A or level B RFI standards when driving steady state loads. When power units are used in "real" situations, driving active electronic circuits, especially those featuring high speed and/or high power switching, the characteristics of the interference generated can change dramatically, thereby reducing the effectiveness of the line filter. It is the final equipment as an entity, that is required to conform to the regulations, not the individual internal sub assemblies. So, specifying a power supply which meets the required RFI level does not remove the need for testing of the completed equipment for conformity.

Internal AC wiring between power unit input terminals and the equipment AC input receptacle, or between the receptacle and other AC driven units (fans, motors, lamps etc.) may well pick up interference which totally bypasses the power units line filters.

The employment of RFI compliant power units is not a guarantee of system compliance.

Design for EMC

Electronic systems must be designed from the outset with EMC considerations in mind. To ensure system conformity to the necessary standards an AC input line filter should be located in an optimum position adjacent to, or integrated with the AC input receptacle. Internal AC and DC distribution wiring should be in twisted pairs, taking the shortest possible routes, should not be bundled together in looms, and should cross other internal wiring at right angles.

The most susceptible wires need to be shielded within a grounded conductive sheath. To keep radiated noise within bounds, known sources of RFI, such as CRT's, HF ballasts and switched mode converter transformers must not be sited adjacent to vent holes or other openings in metal enclosures.

Switched Mode Power Converters

All varying electric currents and magnetic fields generate Electro Magnetic Interference. The more rapid the variation, the higher the amplitude and the broader is the frequency band of the noise emissions generated. Because they employ fast switching transitions at high power, switched mode power converters are a major source of broad band noise. In consequence they tend to incorporate comprehensive line input filters. Typically these filters are similar to those illustrated in Figs 11a and 11b for level A and Level B compliance respectively.

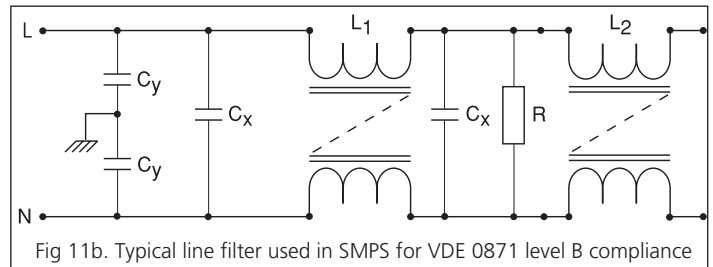
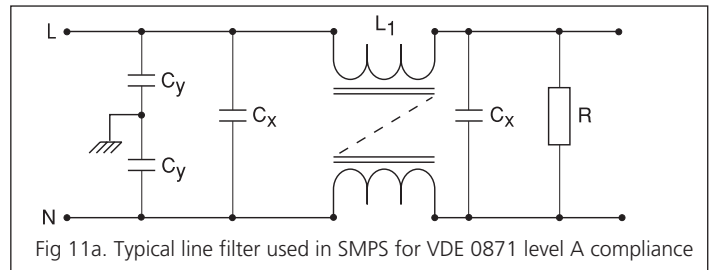

Pre-Test Checklist

1. If a line fuse is fitted, ensure that it is correctly rated.
2. For mains operated units check that the input voltage selector is set for the correct voltage.
3. The following safety precautions are advised before switching on mains operated units.
 - Connect the power supply protective earth terminal to an external safety earth conductor
 - If testing is to be carried out on a bench, cover the bench top with insulating material of 2mm minimum thickness
 - Where mains inputs terminals or live uninsulated high voltage conductors, such as PCB tracks are exposed, a safety screen should be used between the unit under test and the test operative

Basic Tests

Basic tests which most users carry out on power converters are the measurement of line and load regulation and output ripple and noise.

Comprehensive testing is beyond the scope of this guide, so only basic tests are covered with a mention of some additional tests that can be carried out once the test equipment is in place.

A useful test set up for regulation testing is shown in Fig. 12. This can be used for linear and switched mode power supplies and for DC/DC converters if the auto transformer is replaced by a well regulated adjustable laboratory power supply.

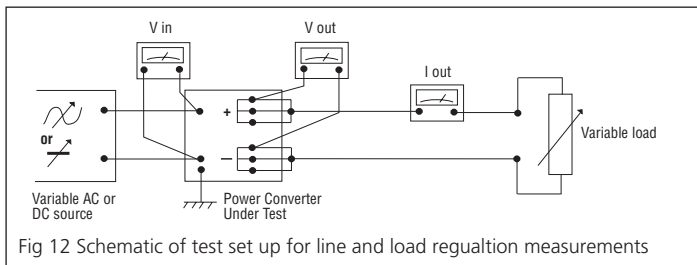

Fig 12 Schematic of test set up for line and load regulation measurements

Minimising Measurement Errors

1. Use adequately rated AC and/or DC variable power sources so that high current peaks drawn by switched mode converters do not drive the source into saturation or current limit. The current rating of the source should be equal to at least 3 times the maximum VA rating of the converter under test divided by the minimum test input voltage.
2. Voltmeters must be connected to the terminals of the converter under test to prevent measurement errors caused by voltage drops in the connecting leads.
3. If the converter has multiple pins for output and return connections it is advisable to use all the pins in parallel to connect the load. This avoids voltage drops due to high connector resistance.
4. Ensure that the area where testing is carried out is at a reasonably constant temperature. Incoming goods areas which are subject to cold draughts of outside air are not suitable environments for carrying out accurate measurements.
5. For switched mode power converters, the output current should be set at the minimum rated load before any testing commences. The majority of such converters require at least 10% loading to regulate, therefore checks carried out with zero load are meaningless.

Line Regulation

At full rated load the output voltage is recorded with the line input voltage at nominal, then at high line and low line. Line regulation is the maximum of the two voltage deviations recorded expressed as a percentage of the output voltage at nominal input.

Load Regulation

With the input voltage set to nominal, the output voltage is recorded at minimum and maximum rated loads. Load regulation is the difference

between the two recorded voltages expressed as a percentage of the output voltage at maximum rated load. Many switched mode power supplies have load regulation expressed as a \pm percent deviation at $60\% \pm 40\%$ of rated load, and the measurement procedure can be modified appropriately.

Other Measurements

Other simple measurements that can be carried out with the test set up illustrated are output current limit, short circuit output current and output setting accuracy.

Electronic Loads

Where testing is expected to be carried out frequently, the acquisition of a set of wide range electronic loads such as the Powerload 50 and 500 is recommended. These combine adjustable load, load current and voltage measurement in one compact unit, greatly reducing set up time especially for multiple output power converter testing. If regulation measurements give worse values than expected, an external voltmeter can be used to check the difference between the voltage at the output terminals and the voltage registered by the electronic load internal voltmeter.

When large numbers of power converters are to be tested, computer controlled testing is a great time saver. With a digital to analogue interface unit like the PC 4400B Powercontroller, programmable electronic load(s) such as the Powerload 50 and 500, and a PC fitted with a GPIB card a very effective high speed test station can be assembled. Complete testing of a power converter, similar to the manufacturers production tests can be carried out in less than one minute.

Temperature Coefficient

With the test set up illustrated in Fig. 12, but with the power converter under test in an enclosed temperature chamber, output voltage temperature coefficient can be determined. The input voltage is set to nominal and the output current to maximum rating and the temperature chamber to 25°C . After allowing time to stabilise the output voltage V_o is recorded. The chamber is then set to 0°C , or the converters minimum specified operating temperature if this is higher, and the temperature allowed to stabilise. This could take as long as 30 minutes, dependent on the size of the chamber and the VA rating of the unit under test. If the air in the chamber is stirred by a low speed paddle bladed fan, the time to reach temperature stability is shortened. When stability is reached the output voltage is again recorded. The chamber is reset to $+50^{\circ}\text{C}$ or the converter maximum operating temperature if this is lower, and the measuring procedure repeated. The two output voltage deviations from V_o are expressed as a percentage, then divided by 25 to obtain the temperature coefficient in $\%/^{\circ}\text{C}$.

The temperature coefficient is the higher of the two numbers, although it is sometimes taken as the average of the above two measurements and quoted as "typical" in the specification.

Output Ripple and Noise

This is a relatively simple measurement for linear AC/DC power supplies and readily available general purpose laboratory test equipment can be used, a low bandwidth oscilloscope for peak to peak measurements and a true RMS voltmeter being ideal. The ripple waveform is 100Hz (or 120Hz for 60Hz operation) with very little high frequency content.

Switched Mode Converters

Because of the high frequency content in the output noise waveform, and the proximity of radiated emissions from the converter it is impossible to make valid measurements without special test equipment. One of the methods used to avoid the measurement being swamped by pick up is shown in Fig. 13. This is a specially adapted oscilloscope probe with an external ground band and a very short unshielded tip. To make the measurement the ground band is held against the output common terminal whilst the tip is in contact with the adjacent output terminal. There is still a small antenna loop created by the probe tip and output terminals. Residual pick up can be reduced by connecting a 0.1 μF ceramic capacitor across the output terminals if necessary. A probe with a conventional ground clip

TECHNICAL ENGINEERING NOTES

Testing Power Converters

connection would be useless for this measurement. Recommended minimum bandwidth for the oscilloscope is 20MHz.

The output ripple waveform of most switched mode converters is triangular pulses at switching frequency with HF noise and spikes superimposed.

The RMS value which is usually less than 10% of the peak to peak amplitude is therefore not often quoted. AC/DC switched mode converters also have mains related ripple content in the output.

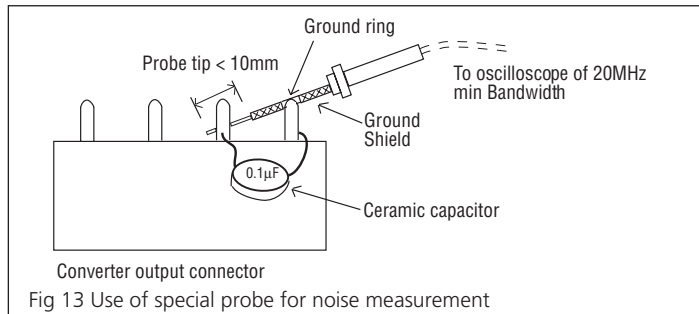

Another method which can be used to obtain accurate measurements is to use a 50W terminated coaxial cable between the converter and the oscilloscope. Fig. 14 shows this technique used to measure DC/DC converter output noise.

With a high quality conductive ground plane (a sheet of copper or aluminium is acceptable) in place between the converter and the oscilloscope, the shielded low impedance interconnecting wires will pick up very little extraneous noise. To minimise the effects of common mode noise an input balun is connected to the converter input. With this method of measurement the actual noise is double the peak to peak value displayed on the oscilloscope, since the terminated coax divides the signal by 2. To obtain accurate measurements the load must have a very low reactance at the switching frequency, preferably below 2%. The coupling capacitor C can be a low ESR electrolytic type, not less than 10µF.

Reflected Ripple Current

This is an important parameter for DC/DC converters because they are sometimes supplied from relatively high impedance sources, or they are at the end of long supply wires. It occurs in all switched mode converters because during switching action very short duration high current pulses are demanded.

Suppression is by internal Pi configured LC filters. A typical measurement technique is shown in Fig. 15 using a wideband current probe and oscilloscope.

Because of the HF content it is usually quoted as a peak to peak current into a specified source impedance.

Common Mode Noise

This is current noise which is common to each output terminal. It flows to the input via the external ground. Again a suitable measuring technique uses a wideband current probe and oscilloscope to obtain peak to peak values. Fig. 16a illustrates the test set up. An alternative method using a low impedance 50W terminated coaxial transmission line is also illustrated (Fig. 16b).

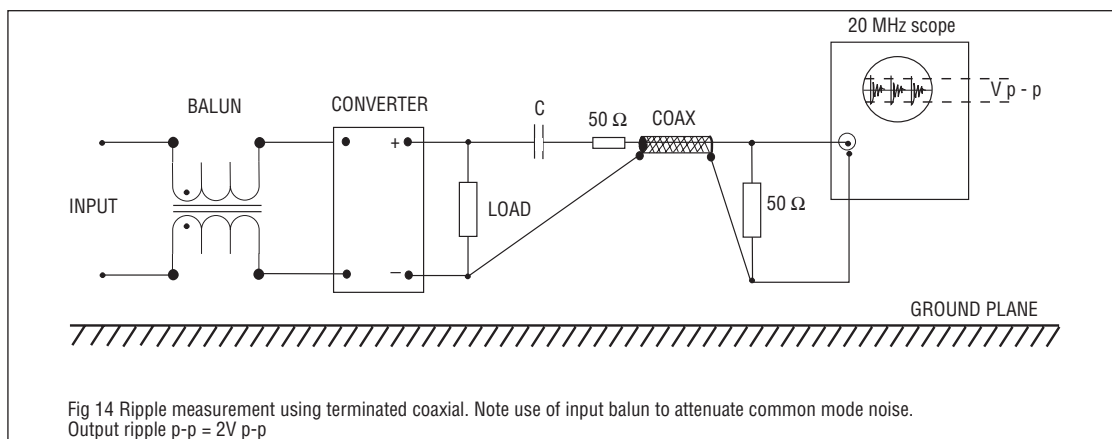
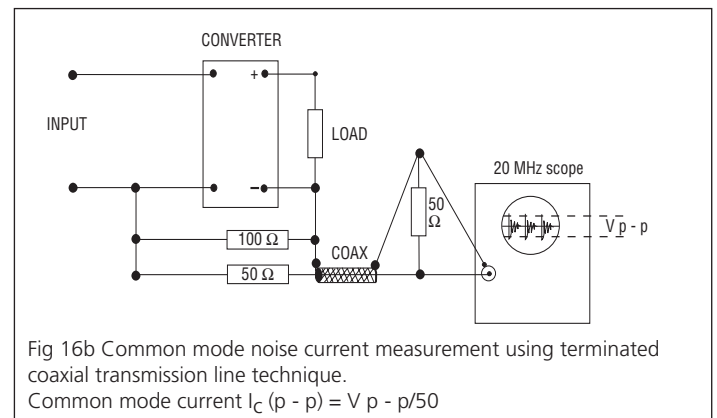
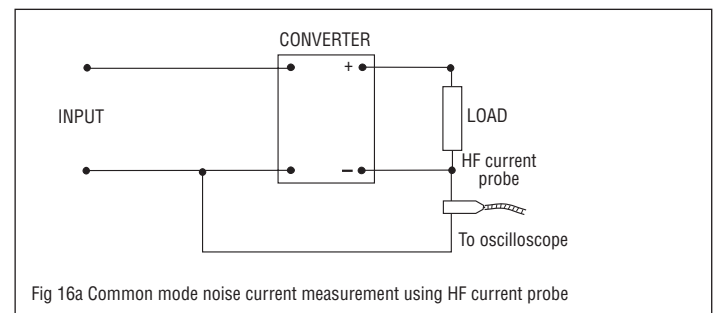
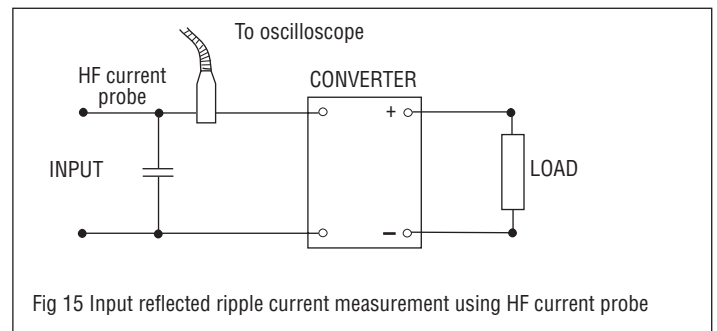

Introduction

It could be argued that there is no need for the user of power conversion products to have any interest in the principles of power conversion. All that is necessary is to match a "black-box" with the requirements of the application.

Provided output ratings, noise and ripple, input range, size, shape, connectors, safety and RFI standards etc., are all acceptable, what is inside the "black-box" is not important. The knowledge that busy design engineers are up against ever shorter development time targets lends sympathy to this view. Powerbox believe that some appreciation of the various circuit topologies in present day use is necessary to optimise selection of the power converter for a specific application.

Linear Power Supplies

Written off by many as "yesterday's technology", dubbed bulky, heavy and inefficient, they still power 50% or more of electronic equipment in use throughout the world.

The advantages of linear power supplies are listed as a reminder of their useful characteristics.

- Simple, rugged, very reliable, easy to maintain - low cost of ownership
- Moderate purchase price
- Excellent line and load regulation - 0.01% to 0.1%
- Very low output ripple and noise - 1mV to 10mV peak to peak
- Rapid recovery to load transients - 50µs
- Only one safety isolation barrier - mains transformer
- No AC mains on the PCB - therefore no creepage problems
- Very low levels of RFI - lower than class A without filters

Fig. 17 shows schematically the circuit of a linear power supply with a series dissipative regulator.

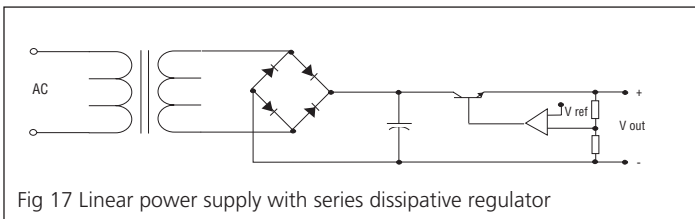

Fig 17 Linear power supply with series dissipative regulator

Switched Mode Power Supplies (SMPS)

Switched mode power supplies were originally developed for military and aerospace use in the 1960s where the bulk, weight and power consumption of linear units were unacceptable. Since then, many different switching circuit topologies and control techniques have been developed. Some of these, in general use in commercial and industrial grade SMPS, are discussed in the following subsections.

Input Rectification and Smoothing

The switching converters used in SMPS are DC/DC converters, therefore the AC supply must be rectified and smoothed to DC with an acceptable peak to peak ripple amplitude.

Almost all commercially available SMPS use the input circuit shown in Fig. 18a to allow operation from 90V to 132V AC RMS and 180V to 264V AC RMS for worldwide use. With the link S open the rectifier diodes are a full bridge configuration producing approximately 320V DC from a 230V AC RMS line input. With S closed, the circuit works as a voltage doubler giving approximately the same 320V DC from an AC line input of nominally 115V RMS. As a voltage doubler, on positive half cycles D1 and D2 conduct, charging C1 to a peak voltage of 160V ($115 \times \sqrt{2}$). On negative half cycles C2 is charged to a negative 160V peak via diodes D3 and D4, so the voltage produced across C1 and C2 in series totals 320V.

To avoid overheating, the electrolytic capacitors must be low ESR types (Equivalent Series Resistance) and their working voltage must be at least 200V. The rectifying diodes must have a high PIV (Peak Inverse Voltage) rating of 600V minimum.

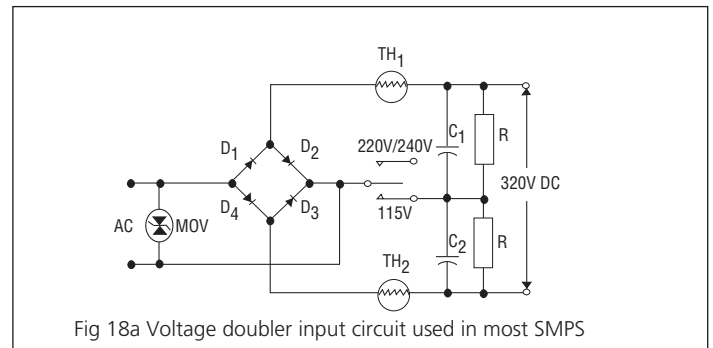

Fig 18a Voltage doubler input circuit used in most SMPS

Inrush Current

When switching on a SMPS with the input circuit of Fig. 18a, the impedance presented to the AC line is the ESR of the capacitors. Without additional series resistance the resulting first half cycle peak current would be hundreds of amperes. TH1 and TH2 are NTC (Negative Temperature Coefficient) thermistors limiting inrush current to a safe value. They have high cold resistance and low hot resistance. Self heating due to current flow causes the resistance to decrease until a low steady state resistance value is attained.

Some medium to high power SMPS employ active circuits with a current limiting resistor which is switched out of circuit by a triac shunt when the capacitors have become fully charged. Product specifications normally advise that inrush current is limited for cold starts (thermistor) or by active means.

Transient Protection

Apart from the line filtering which was discussed under the heading EMC, the other important built in protection device which is connected across the input is a transient line voltage suppressor. This protects the power converter against high voltage mains spikes caused by local inductive switching and electric storms. A suitable device is a metal oxide varistor (MOV) of appropriate voltage and current rating as shown in Fig. 18a.

Wide Input Range

Some equipment manufacturers need to be able to market a standard product worldwide without specifying AC operating range. Responding to this demand, power units are now available which automatically switch between the low and high ranges (in effect replacing the link S in Fig. 18a with an automatically controlled switch).

But low (to medium) power SMPS are becoming available with the ability to operate from 90 to 264V AC in a single continuous range. These units do not need the voltage doubler input circuit, and are usually easily recognisable by the single large 400V rated electrolytic capacitor in the input circuit.

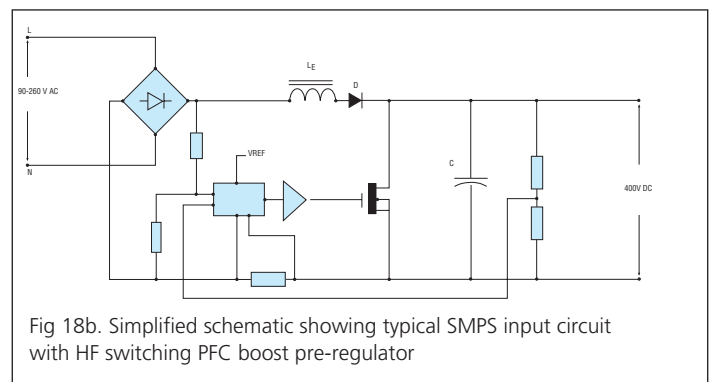

Fig 18b. Simplified schematic showing typical SMPS input circuit with HF switching PFC boost pre-regulator

PFC Input Circuit

Wide input range also comes as a bonus with the use of a switched mode boost pre-regulator for input harmonic current limitation to ensure compliance with EN61000-3-2. The typical scheme shown in Fig 18b functions essentially as follows. The full wave rectified input voltage is used as the reference input for a current mode switching regulator. This controls the rapid charge and discharge of the energy storage choke LE , forcing the average input current to track the reference waveform. An overall voltage control loop regulates the output voltage to approximately 400VDC. Initially, SMPS designers implemented such schemes with discrete component controllers. There are now available a number of integrated circuit PFC switching controllers. Typically they would comprise a current multiplier, precision voltage reference, error amplifier, oscillator, PWM with output gate drive, and input under/overvoltage detection and shutdown, all in a standard 16 pin DIP. Controllers of this type allow input voltage operation from 90V-260VAC and result in power factors from 0.95 to 0.99. A further benefit is that the output voltage across the storage capacitor C is constant; therefore the energy stored is constant. Output hold up times then depend only on the load. It is constant for fixed loads, not at all dependent on input voltage level.

Types of Switched Mode Converters

Converters based upon the following topologies may be found in both AC/DC SMPS and in DC/DC converters.

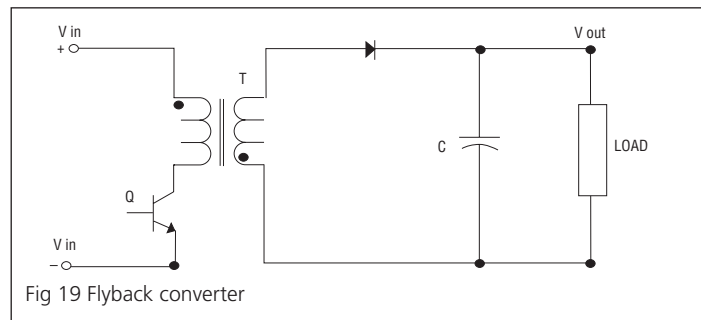

Flyback Converter

Because of its circuit simplicity and low cost this has become the favoured topology for the majority of low power converters (up to 100 watts). Fig. 19 shows the fundamental principles of flyback conversion. When Q conducts, current rises linearly in the primary of the transformer. The transformer is designed to have a high inductance so that energy is stored as the flux builds up. Winding polarity ensures that diode D is reverse biased during this period so no transformer secondary current flows. When Q turns off, flux in the transformer decays generating a secondary current which flows to the load and charges capacitor C . Energy is stored in the transformer field during the "on" period of the switch Q and transferred to the load during the "off" (flyback) period. Capacitor C is a reservoir maintaining voltage across the load during the "on" period. Regulation of the secondary voltage is achieved by comparing the output voltage with a reference voltage and using the difference to vary the "on" time of Q . Energy transfer to the secondary is therefore controlled to maintain secondary voltage independently of load and supply voltage changes.

Varying the "on" time of Q may be carried out by pulse width modulation (PWM) driven at a constant frequency by a local oscillator, or, in the simplest and lowest cost schemes, by self oscillation. In this case as the load changes, the frequency varies to vary the "on" time.

Multiple Output Flyback Converter

Figure 20 illustrates the simplicity of adding isolated outputs to a flyback converter. For each output an extra secondary winding, a diode and a reservoir capacitor are the basic requirements. To provide load regulation for the auxiliary outputs, three terminal series regulators are often used, at the expense of decreased overall efficiency.

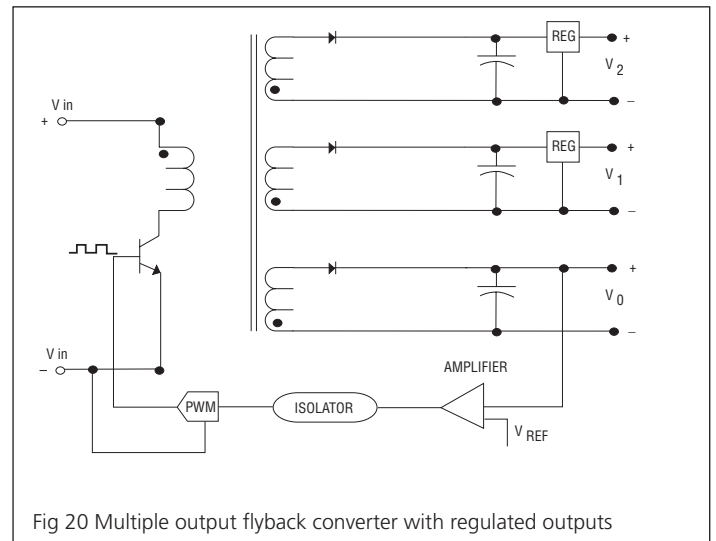

Fig 20 Multiple output flyback converter with regulated outputs

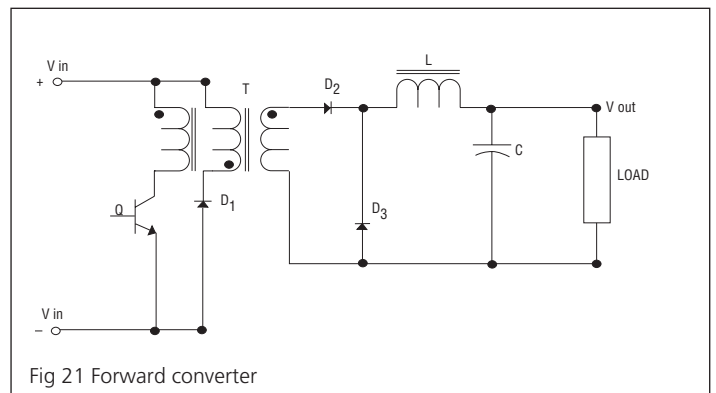

Fig 21 Forward converter

Forward Converter

The forward converter is cost effective from 100 to 250 watts. As Fig. 21 shows, it is more complex than the basic flyback circuit, but its operation is still fairly simple. When switching transistor Q is turned "on", current builds up in the primary and secondary windings simultaneously. Because winding polarity forward biases D_2 , secondary current flows via L to the load and flux builds up in L creating an energy store. Q turns "off", primary current

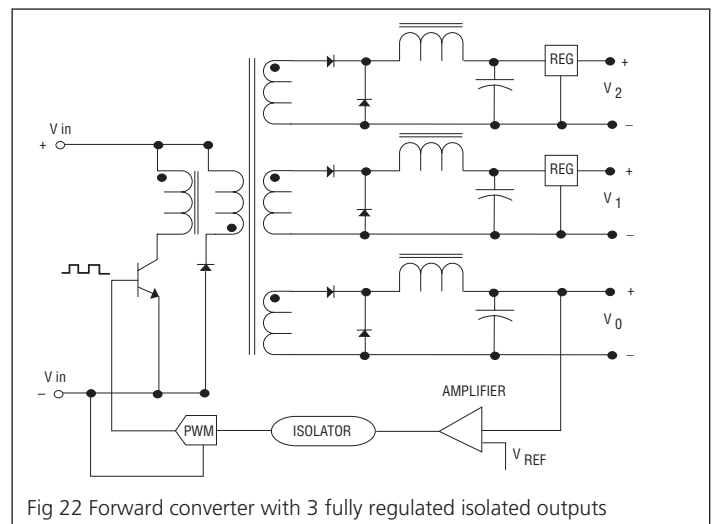

Fig 22 Forward converter with 3 fully regulated isolated outputs

collapses reversing the secondary voltage. D2 is now reversed biased blocking current flow in the transformer secondary, but D3, the "flywheel" diode, now conducts allowing L to discharge into the load. The third winding shown allows energy remaining in the transformer leakage inductance at the end of the "on" cycle to be returned to the primary DC bus via D1. This winding is sometimes called the reset or demagnetisation winding. Unlike the flyback converter current flows from the energy storage inductor to the load during on and off times of the switch Q resulting in half the peak currents in the secondary diodes and inherently lower output ripple.

Multiple Output Forward Converter (Fig. 22)

For each additional isolated output an extra secondary winding is needed on the transformer with two fast recovery diodes, an energy storage inductor and a filter capacitor. The diodes must each be capable of supplying the full output rating. The additional components make the circuit realisation more expensive than the simpler flyback converter. Series regulators can be used to improve the regulation of the auxiliary outputs.

Push Pull Converter (Fig 23)

To make more efficient use of the magnetic cores push pull converters have been developed. Essentially the push pull converter consists of two forward converters driven by antiphase inputs. The two diodes D1 and D2 in the secondary act as both forward and flywheel diodes. Ideally conduction times of Q1 and Q2 are equal, the transformer is driven symmetrically, and unlike the single ended converters, because there is no DC component in the drive no air gap is necessary in the magnetic path. This results in approximately half the core volume for the same power.

A major difficulty arises with this circuit because the transformer saturates if the characteristics of the switching transistors are not precisely matched. Core saturation results in rapid thermal runaway and destruction of one of

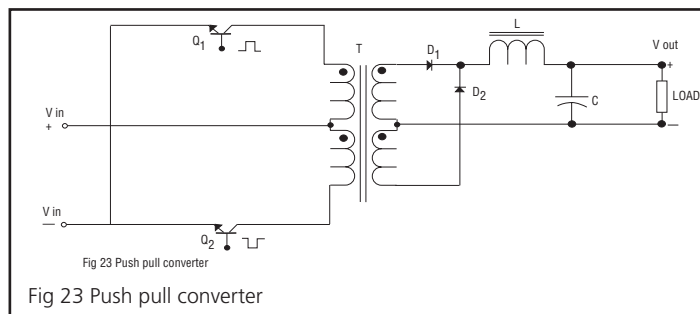

the transistors. Solutions to this problem are complex and expensive. So for higher power (200 watt plus) applications, half bridge and full bridge converters have been developed.

Half Bridge Converter

This has become the most popular converter technique for the 200 to 400 watt power range, extending to 600 watts with integral forced cooling. From Fig. 24 it can be seen that the transformer primary is connected between the junction of the input bridge reservoir capacitors, which is floating at a nominal voltage of 160V DC (half peak rectified AC supply voltage) and the junction of Q1 emitter and Q2 collector. Antiphase pulsing of Q1 and Q2 alternately connects the transformer to the positive and negative input DC bus generating a 320V peak to peak square wave which is stepped down, rectified and filtered to produce the required DC output voltage.

One advantage is immediately obvious. Even with switching spikes unsuppressed the maximum voltage stress on the transistor switches is the peak rectified supply voltage (V_{in}) whereas in the basic flyback, forward and push pull converters it is $2V_{in}$. Frequently 400V to 500V switching transistors are used in half bridge circuits whereas 800V to 1000V devices are common in single ended configurations. This explains why almost all circuits using MOSFET switches are based upon half bridge designs (or full bridge for very high power).

Unbalanced switching of Q1 and Q2, which in effect creates a DC bias leading to core saturation and transistor failure, is overcome by the series coupling capacitor C3. Regulation is normally achieved by comparing the output with a reference and using the difference to control pulse width. Most PWM control ICs currently available are suitable for use in half bridge converters.

Some of the advantages of half bridge converters are:

- Small magnetic cores
- No magnetic path gap therefore low stray magnetic field
- Frequency seen by secondary circuits is double the basic switching frequency
- Small filter components (L and C) in secondary circuits.
- Low output ripple and noise
- Multiple output configurations easily implemented
- Relatively low radiated noise, especially if the secondary inductors are toroidal cores.

A disadvantage is because they are working at half the supply voltage the switching transistors are working at twice the collector current compared with the basic push pull circuit.

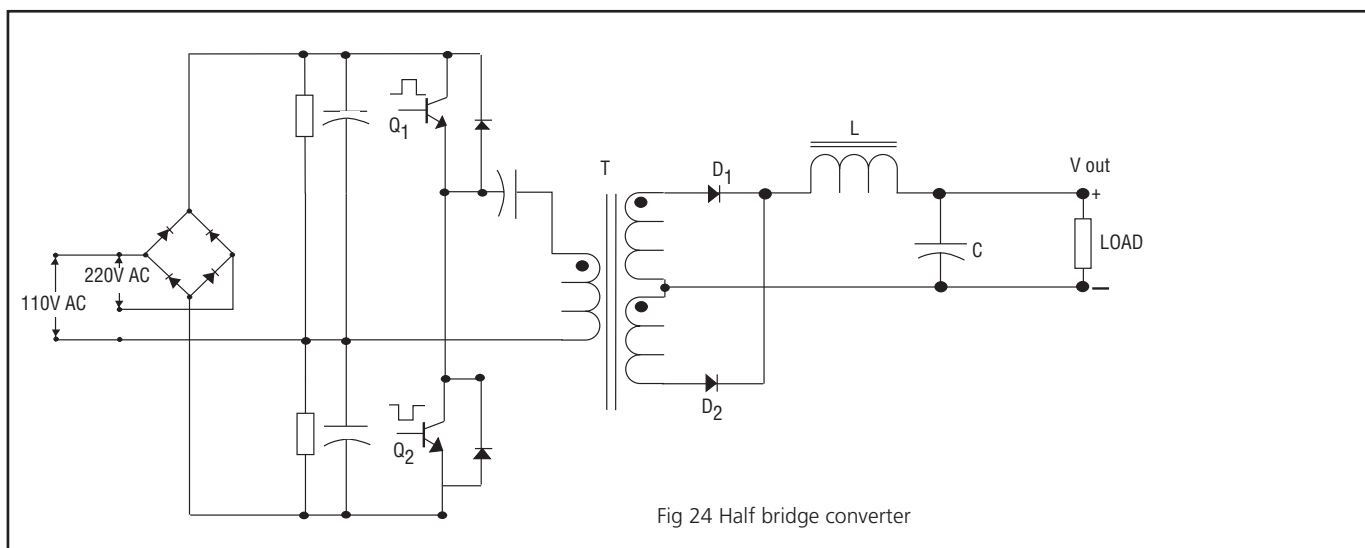

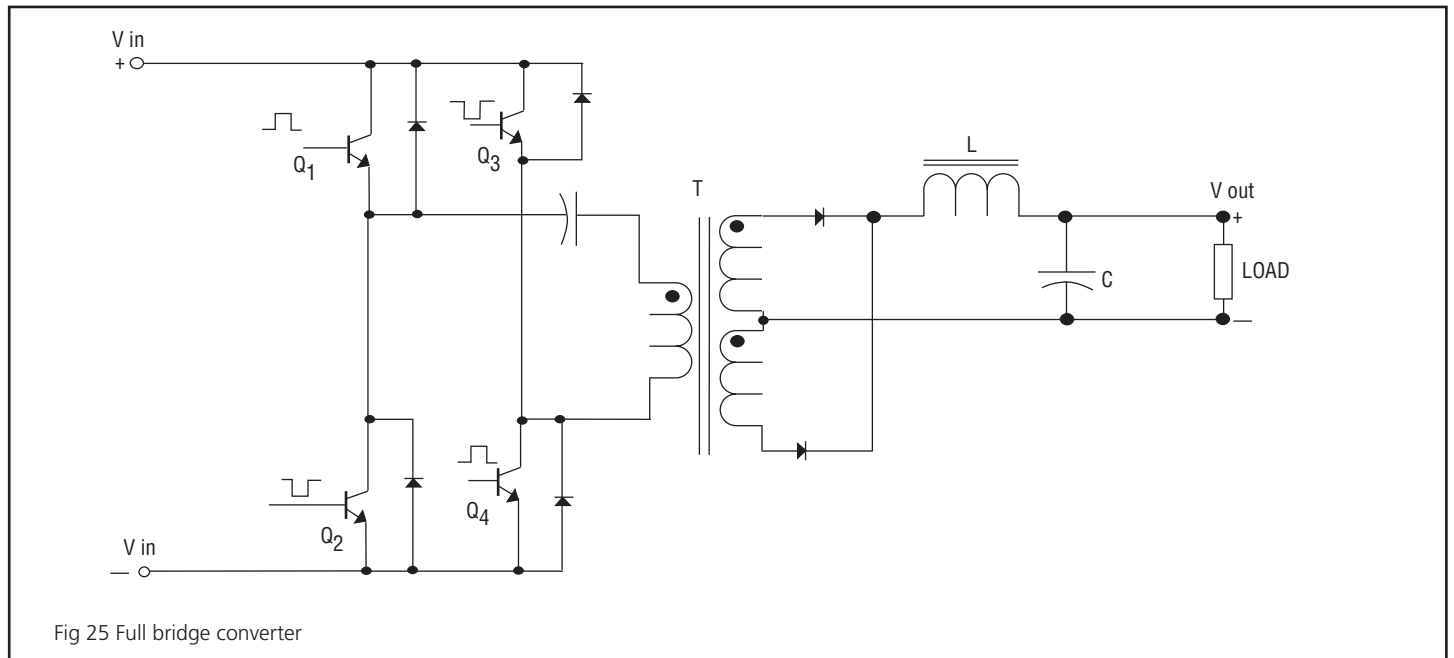

Full Bridge Converter

For powers in excess of 500 watts the collector currents of the switching transistors in half bridge converters become excessive. Fig. 25 shows the basic topology of a full bridge converter where the transistors in opposite arms of the bridge Q1 and Q4 are driven in phase and Q2 and Q3 are driven by the antiphase pulse. The transformer primary is therefore pulsed from $+V_{in}$ to $-V_{in}$ nominally 640V peak to peak), but the transistors are limited to V_{ce} (V_{ce} = collector emitter voltage) of V_{in} and the current is half that of an equivalent power half bridge. The use of four switching transistors which must each have an isolated drive makes the full bridge topology expensive.

The much simpler and lower power gate drive circuits required by MOSFETS when compared with the complex base drive requirements of bipolar transistor switches greatly favours their use in high power full bridge circuits. The higher switching frequencies achievable with MOSFETS gives considerable size advantages in the transformer core and in filter components. This is well illustrated by referring to the Power Ten range of high power rack mounted units.

Current Mode Control

Although not a new concept, this method of controlling switched mode converters has only recently become popular. This is because of the widespread availability of integrated circuit control elements containing PWM and current mode control circuits in a single inexpensive IC.

Current mode control uses dual feedback loops. There is the conventional output voltage feedback loop via an error amplifier, and a second loop which senses the current in the output inductor (primary of the converter transformer) and compares this with the error amplifier output. The switching transistor is switched on by the start of the clock pulse, but ends its conduction phase when the inductor current is sufficient to null the output of the error amplifier. Fig. 26 shows a simple schematic circuit illustrating the main features of current mode control.

Advantages of current mode control are improved transient response and dynamic stability, inherent current limiting and easy current sharing in parallel schemes. A basic voltage regulated switched mode converter is a third order control system. This requires compensation to limit the loop gain

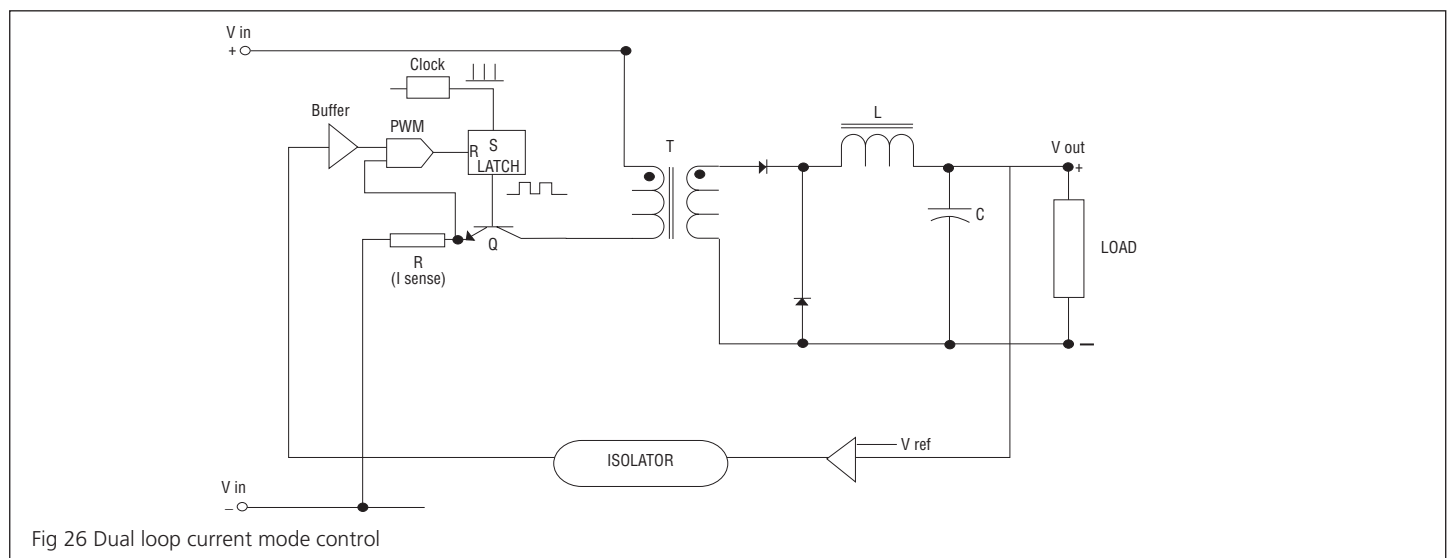

at high frequencies. Therefore dynamic performance is poor and there is a tendency to “ringing” when subjected to transient disturbances. Adding current mode control converts the open loop to a first order system (one dominant pole) making stabilisation easy and allowing a higher gain bandwidth product. This improves transient response without any tendency to “ring”.

A further claim for current mode control is that it is “EMC friendly”, because the tight current control prevents the transformer saturating. The major source of radiated noise in conventional switched mode converters is the transformer flux leakage which is maximised when the transformer core saturates (on peak current demands for example). Another noise source is “ringing” under transient conditions and as pointed out above this is minimised by the good stability characteristics of current mode control. Current mode control is relatively easy to implement with flyback and forward converters, but more difficult with push pull and bridge types especially for multiple output configurations.

Resonant Mode Conversion

In the quest for higher power densities, designers have been increasing switching speeds in power converters. 100kHz is now relatively common in converters using conventional PWM control. Above this frequency switching losses, component limitations and EMI pose problems which are difficult to overcome at reasonable costs. Some of the drawbacks encountered by square wave switching at high frequencies are virtually eliminated by using resonant mode techniques.

The two important characteristics of resonant mode conversion are that switching occurs at zero current so there are no switching losses, and the current waveform is essentially sinusoidal resulting in low di/dt , low switching stresses in components and no broadband EMI. There are many different ways of implementing resonant mode conversion. When combined with a fixed frequency PWM control the term quasi-resonant switching is often used. Most commercially available resonant converters achieve regulation by fixing the on or off time of the switch and modulating the frequency.

There are two fundamental resonant mode topologies, series loaded and parallel loaded as shown in Fig. 27. The LC combination is known as the resonant tank circuit and could be on either the primary or secondary side of the converter.

Primary side resonance as shown in Fig. 28 is more commonly used. Benefits of resonant mode techniques start at switching frequencies around 200kHz and continue up to 2MHz. With zero voltage switching as an alternative approach to zero current switching experimental models operating at switching frequencies up to 10MHz have been reported.

One of the disadvantages of resonant mode conversion is that multiple output units based upon a single converter are not practicable. The only practicable solution is one converter per output which is expensive by comparison to conventional converters. A quasi-resonant parallel converter configured as a half bridge driving an LC tank circuit in the primary side is a good compromise which does allow multiple outputs while conferring the benefits of zero current switching, sinusoidal current waveform and high frequency operation.

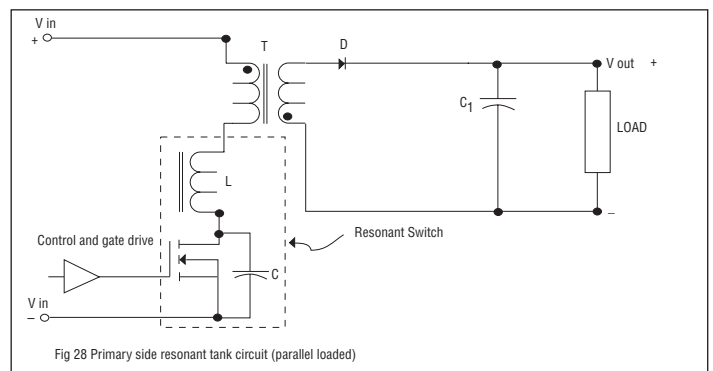
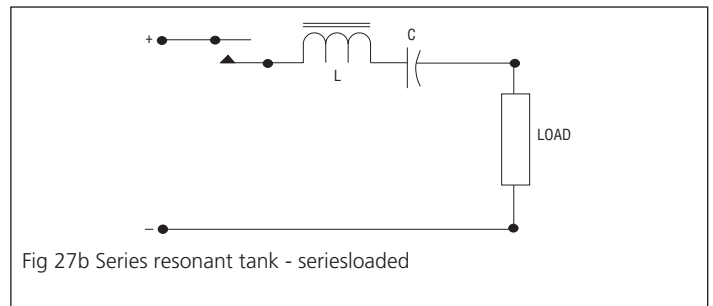
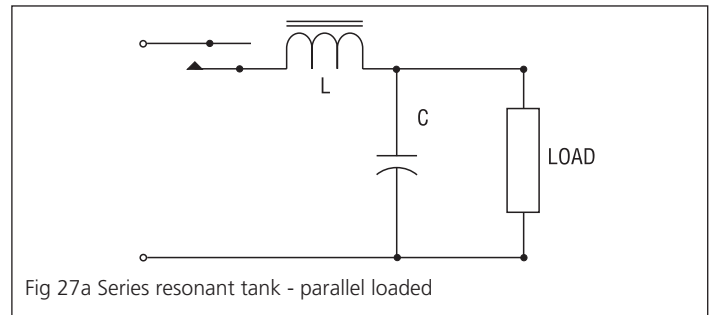

Facts regarding WEEE and RoHS Directives

There are two new European EC Directives that will be implemented and affect the electronic industry the coming years. The two directives are **Waste Electrical and Electronic Equipment (WEEE) Directive 2002/96/EC** and **Restrictions of the Use of Certain Hazardous in Electrical and Electronic Equipment (RoHS) Directive 2002/95/EC**. The objectives with these directives are to limit the environmental stress and to protect human health.

WEEE Directive

This directive came into force from August 13th, 2005
The directive covers 10 categories of products:

Categories

1. Large household appliances
2. Small household appliances
3. IT & telecommunications equipments
4. Consumer equipments
5. Lightning equipments
6. Electrical and electronic tools
7. Certain toys, leisure and sports equipments
8. Medical devices
9. Monitoring and control instruments
10. Automatic dispensers

Producers shall guarantee financing of the collection, treatment, recovery and recycling of collected WEEE.

The definition "Producers" does cover anyone who:

- manufacture and sell electrical and electronic equipment under own brand
- resells equipment produced by other supplier under own brand
- is importing or exporting electrical and electronic equipment on a professional basis

RoHS Directive

From 1st July 2006, new electrical and electronic equipment placed on the market shall not contain:

(The proposed limits are 0.01% for cadmium and 0.1% for all other substances by weight in homogenous substances.)

Lead (Pb)

Mercury (Hg)

Cadmium (Cd)

Hexavalent chromium (CR VI)

Certain brominated flame retardants (BFR)

Polybrominated biphenyls (PBB)

Polybrominated diphenyl ethers (PBDE)

The directive covers the same categories as WEEE except for Medical devices and (Monitoring and control instruments).

For ease of use, Craftec use a standard format for power conversion product specifications. The following terms and related definitions are listed in the same order as they appear in a typical product specification.

INPUT			
Voltage	Nominal RMS value(s) of Ac sinewave mains voltage(s) for which the converter is designed.	Voltage balance	The difference, expressed as a percentage between the voltage magnitudes of a twin output converter, where the outputs have the same nominal voltage but the opposite polarity.
Nominal voltage	Typical frequently used input DC voltages for which the converter is suitable.	Voltage adjustment	The range over which the output voltage can be adjusted (and the means of adjustment).
Voltage range	The range(s) of input DC voltage(s) over which the converter(s) operates within specification.	Current adjustment	The range over which the output current can be adjusted (and the means of adjustment).
Frequency	The range of mains frequency over which the converter operates within specification.	Resolution	The smallest incremental step adjustment possible by use of built-in controls.
Current at no load	The current drawn by the converter from the supply when the load current is zero and the input supply voltage is at the low end of the specified range.	Ripple and noise	The sum of all the voltage noise components expressed as a peak to peak amplitude over a specified band width.
Current at full load	The current drawn by the converter from the supply when the load current is at maximum rating and the input supply voltage is at the low end of the specified range.	Switching spike	The peak to peak amplitude of the voltage spike which occurs at switching frequency on the output of switched mode converters.
Reflected ripple	The AC current generated at the input of a DC/DC converter by the switching action of the converter.	Drift	A change of output voltage over a period of time, independent of input, load and temperature variations.
Protection	Indicates if the converter is fused internally. The recommended fuse rating for the power supply may be given.	Overvoltage protection	A circuit which detects output overvoltages above a specified level and shuts down the converter to protect load circuits.
Reverse voltage prot.	Protection circuit built into the input of the converter to prevent damage if a reverse polarity voltage is applied to the input.	Reverse voltage prot.	A built-in circuit (or element) that protects the converter from a reverse polarity applied across the output terminals.
Isolation	The electrical separation between the input and output expressed as a DC test voltage, and a resistance with parallel capacitance.	Short circuit protection	Automatic output current limiting to prevent damage to the converter when a short circuit is applied across the output terminals.
Safety isolation	The electrical separation between the primary and secondary circuits and the safety standards to which the converter conforms in this respect.	Overload protection	A protective feature that limits output power or current demands to prevent damage to the converter.
Filter	Indicates built in line input filter to attenuate reflected ripple current.	Current limit adjustment	The range over which the protective current limit can be adjusted (and the means of adjustment).
OUTPUT		Thermal protection	An internal temperature trip that shuts down the converter if the internal temperature exceeds a predetermined limit.
Power	The maximum continuous power measured in watts that can be taken from the output (s) of the converter.	Temperature coefficient	The percentage change in output voltage per °C change in external ambient temperature averaged over the specified full rating operating temperature range.
Turn on delay	The time in seconds after switch on for the output(s) to reach their nominal voltage(s) within regulation limits.	Impedance	The apparent impedance presented by the converter to its output terminals.
Overshoot	A transient change in output voltage in excess of specified regulation limits.	Efficiency	The ratio of total output power to total true input power expressed as a percentage.
Line regulation	The percentage change in output voltage caused by the input voltage varying over the specified range. This range is either mentioned, or is the actual input voltage range.	Hold up time	The minimum time the converter output(s) remain in regulation after loss of input power under full rated load and nominal input voltage conditions.
Load regulation	The percentage change in output voltage caused by a specified load variation.	Power fail	A logic compatible signal warning that the outputs will fall outside regulation limits due to the loss of input power.
Cross regulation	The percentage change in output voltage of one output caused by a specified load variation on another output of a multi-output converter.	Minimum load	The load current that can be taken from a converter output, below which regulation is not guaranteed.
Transient response	The maximum time for the output voltage to return within regulation limits following a specific load step change.	Parallel operation	The ability of two or more converter outputs set to the same voltage to be connected in parallel to provide increased output current.
Setting accuracy	The percentage difference between the actual voltage setting and the nominal output voltage at rated load and nominal line input voltage.	Series operation	The ability of two or more converter outputs to be wired in series to provide a higher output voltage.

TECHNICAL ENGINEERING NOTES

Glossary of Terms

Remote sense	A method of compensating the deterioration of regulation caused by the resistance of load connection lead. Accomplished by sensing the output voltage at the load and using the difference between this voltage and the internal reference to regulate the output voltage.
Programming	The control of converter output voltage and/or current by varying an external parameter (voltage, current or resistance).
Remote adjustment	The ability to vary output voltage and/or current over a specified range by an external control.
Remote inhibit	Converter shutdown into a standby or idle mode by application of an external signal to the inhibit terminal.
Input common	Normally referenced to the negative side of the converter input.
Logic compatibility	Type of logic signal that can be used without level change or impedance transforms.
On control input voltage	Logic "hi" threshold.
Off control input voltage	Logic "lo" threshold.
Shutdown idle current	Current drawn by the converter from the supply in standby.

ENVIRONMENTAL

Operating temperature	The range of ambient or baseplate temperature in °C over which a converter can be operated safely at either rated or derated output power.
Derating	The output power reduction required for safe operation above a specified temperature, usually expressed as a % reduction per °C up to the maximum operating temperature.
Storage temperature	The range of ambient temperatures over which a converter may be stored long term without damage. Expressed in °C.
Cooling	The process of removing heat dissipated internally within the power converter during normal operation. This may be by natural convection, or conduction to a baseplate, or by forced air.
Humidity	The maximum moisture content in the surrounding air for operation of the converter over the specified operating temperature range. Expressed as a percentage, it is the ratio of the actual mass of water vapour present to the mass of water vapour in the same volume of saturated air at the same temperature and pressure.
Altitude	The maximum altitude at which the converter can be used without derating.
Shock standards	Definition of the mechanical "bump" tests that can be applied to the converter without damage.
Vibration standards	Definition of the amplitude and frequency of mechanical vibration that can be applied to the converter without damage.

GENERAL

MTBF	The predicted average length of time (Mean time between failure) between failures exclusive of infant mortality and end of rated life.
MTTR	The predicted average length of time to (Mean time to repair) repair a faulty unit with the specified spares kit.
Safety leakage current	When the input voltage is at nominal, the current flowing from the input lines to the protective earth conductor.

RFI standards	Limits laid down by various national and international regulatory agencies for radio frequency interference generated by electrical and electronic equipment (see Section 3).
Design topology	The conversion principle employed (eg. linear, switched mode flyback, half bridge etc).
Switching frequency	The typical frequency of the converter switch at full rated load.
External synchronisation	The ability to synchronise the converter switching frequency to an external oscillator.
PCB mounting	Designed for direct mounting onto printed circuit boards.
Chassis mounting	Designed for mounting to a metal or other rigid surface in the host equipment. The unit has screw terminals for input/output connection.
Encapsulated	Totally encapsulated and hermetically sealed in cast epoxy resin or similar plastic.
Ventilated case	Enclosed in a metal case with ventilation slots for cooling by convected or forced air.
Case grounding	Metal enclosures around converters will normally be connected to ground internally. Some DC/DC converters have insulated cases.
Open card PCB format	Construction of a converter is on a printed circuit board without chassis or cover.
L bracket	Open chassis construction, chassis normally having L shaped cross section.
Cased	Fully enclosed.

STANDARDS

Safety standards	Standards laid down by various national and international regulatory agencies.
Approved	Approval, listing or certification of the converter has been obtained for the standards specified.
Designed to meet	Provided the converter is correctly installed it will not prevent the host equipment from obtaining official recognition to the standards specified.

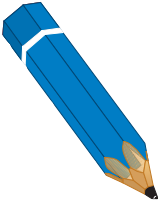

A series of horizontal lines for writing, starting from the top right of the pencil icon and extending across the page.

